

Doors

Systems

Doors

Systems

Sliding Systems
Rasomuro 55 System
Doors
Partitions & Boiserie

06	L16
08	<i>Sliding Systems</i>
10	L7
20	L7 Plus
28	Shoin
44	Shoin Pivot
54	Koan
64	Koan Plus
74	Sliding 50
84	<i>Rasomuro 55 System</i>
86	Rasomuro 55s
98	Rasoline 55s
104	Rasotouch 55s
110	Rasovetro 55s
116	Edge
122	Raso USA
128	Compass 55
144	Sliding Pocket
150	<i>Doors</i>
152	Altaj
164	Ying
174	L7
188	L7 Large
200	L41
210	Lcd62
218	Filo 55 s-t
228	Avenue
236	San Siro
242	Drive
248	<i>Partitions & Boiserie</i>
250	Wall&Door
264	Teatro
272	Boiserie
278	Avenue Boiserie
286	Edge Boiserie
292	<i>Technical drawings</i>
326	<i>Handles</i>
332	<i>Finishes</i>



XXIII ADI
COMPASSO D'ORO
INTERNATIONAL
AWARD

L16

Progettata da Piero Lissoni, L16 è pensata per riduzione. Di spessori, innanzi tutto. Straordinariamente sottile, l'anta battente somiglia a un foglio, una pagina nitida, capace di separare gli ambienti con mano leggera e movimento fluido. Ogni elemento visibile è progettato per scomparire. Quel che si offre allo sguardo è una superficie intatta, ripulita di ogni segno, perfettamente uniforme, vero e proprio elemento architettonico in grado di caratterizzare e definire lo spazio, grazie al risalto di essenze e colori.

Designed by Piero Lissoni, L16 is studied to enable dimensions to be reduced, especially in thickness. Remarkably thin, the hinged door appears as a sheet, an unblemished page, able to separate spaces with a light touch and fluid motion. Each visible element is designed to disappear. To the eye it offers a flawless surface, free of any imperfection and perfectly uniform; a true architectural element able to characterize and define the space, thanks to the prominence of woods and colors.

Il coprifilo di L16, qui in laccato rosso lucido, può diventare un pannello ed estendersi intorno alla porta con un effetto boiserie di grande impatto decorativo.

The profile of the L16, here in red gloss lacquer, can become a panel and extend out from around the door providing a boiserie effect of great decorative impact.



Sliding Systems

[08 - 83]

I sistemi sono un progetto fluido e flessibile per suddividere gli spazi con superfici in vetro o legno, pannelli e porte scorrevoli che si integrano con armonia con l'architettura e l'arredo. Per ottenere leggerezza visiva e soluzioni di continuità negli ambienti interni.

These systems are a fluid and flexible project to divide spaces with glass or wood surfaces, sliding panels and doors that integrate harmoniously with the architecture and furnishings. To obtain visual lightness and continuity in indoor environments.

L7

La leggerezza dell'alluminio, la luminosità del vetro, il design di Piero Lissoni, il background di Lualdi. Nasce L7, una porta contemporanea per concezione, uso di materiale e tecnologie, ma classica per estetica. In versione scorrevole, L7 crea soluzioni perfette, tagliate su misura, per definire spazi domestici e di lavoro. Scandite dalle linee lucenti dei telai, le superfici vetrate sono accese dalla bellezza dei riflessi e delle sfumature di colore.

The lightness of aluminium, the luminosity of glass, the design of Piero Lissoni, the background of Lualdi. The L7 door is contemporary in its conception and use of materials and technologies, but at the same time classic in appearance.

The sliding version of L7 creates perfect solutions, tailored to define both domestic and work spaces. Punctuated by the lustrous lines of the frames, the glass surfaces are illuminated by beautiful hues and shades of colour.

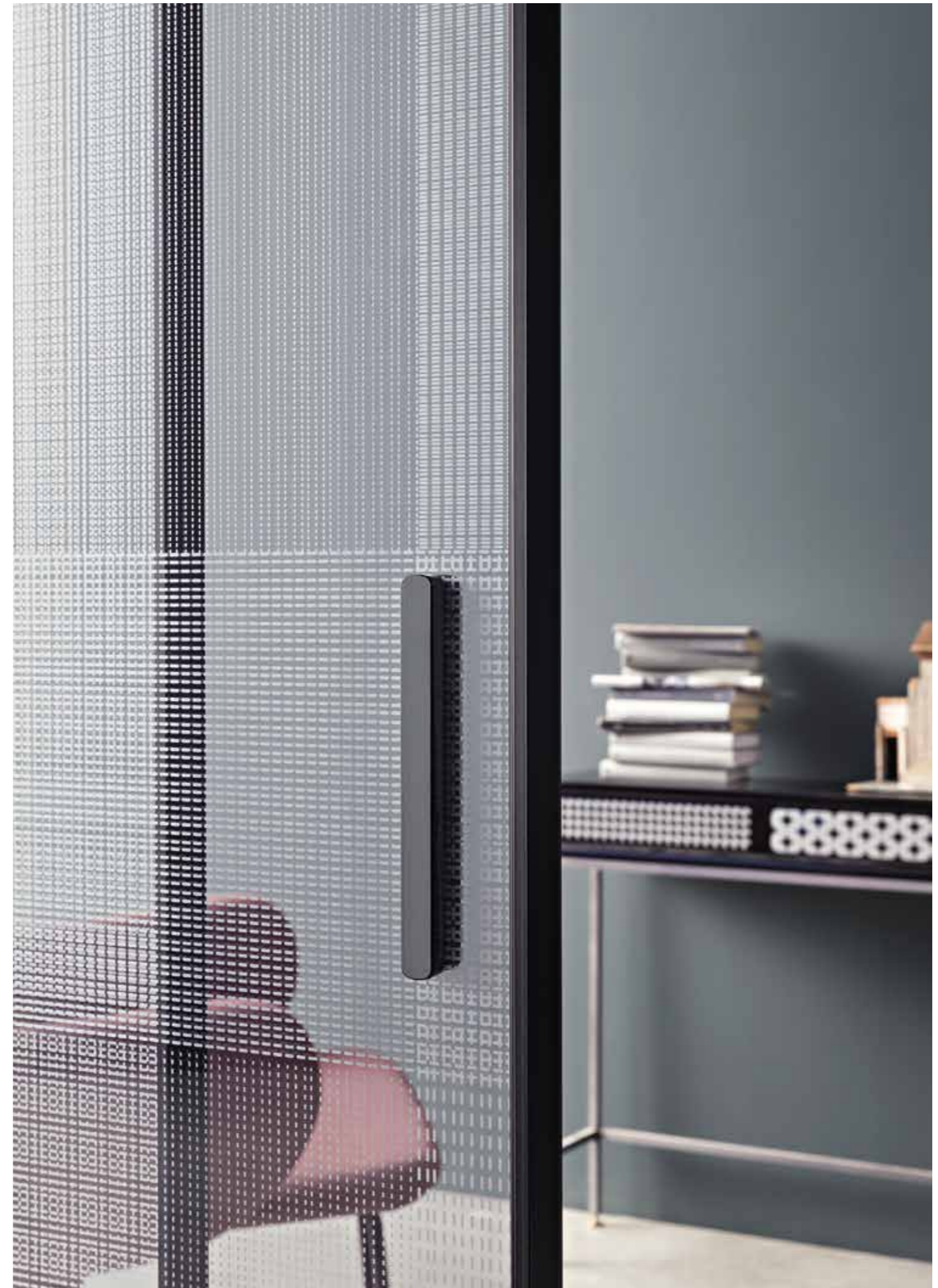



L7 scorrevole con vetro Marks extrachiaro e profilo nero opaco: gli impalpabili decori, sovrappendosi, creano nuove, raffinate grafiche.

The sliding L7 with Marks extra-clear glass and a matt black profile: the impalpable and overlapping patterns create new, sophisticated graphic elements.





L7 scorrevole: una presenza funzionale che diventa elemento spaziale sottilmente decorativo.

L7 sliding version: a functional presence that becomes a subtly decorative spatial element.



L7 Plus

L7 Plus si distingue per una purezza formale del disegno grafico del telaio, data dalle geometrie dei listelli in alluminio sul vetro. La parete divisoria con elementi scorrevoli, disegnata da Piero Lissoni, è l'evoluzione del sistema L7, di cui conserva duttilità e allure contemporaneo, che la rendono adatta ai più diversi ambienti domestici.

L7 Plus is distinguished by the formal purity of the frame patterning, produced by the layout of the aluminum strips on the glass. The partition wall with sliding elements, designed by Piero Lissoni, is the evolution of the L7 system and maintains the same flexibility and contemporary allure that make it suitable for the most diverse domestic environments.





L7 Plus, parete divisoria con elementi scorrevoli in vetro grigio trasparente, telaio e listelli neri.

L7 Plus, partition wall with sliding elements in grey transparent glass, black frame and trim.

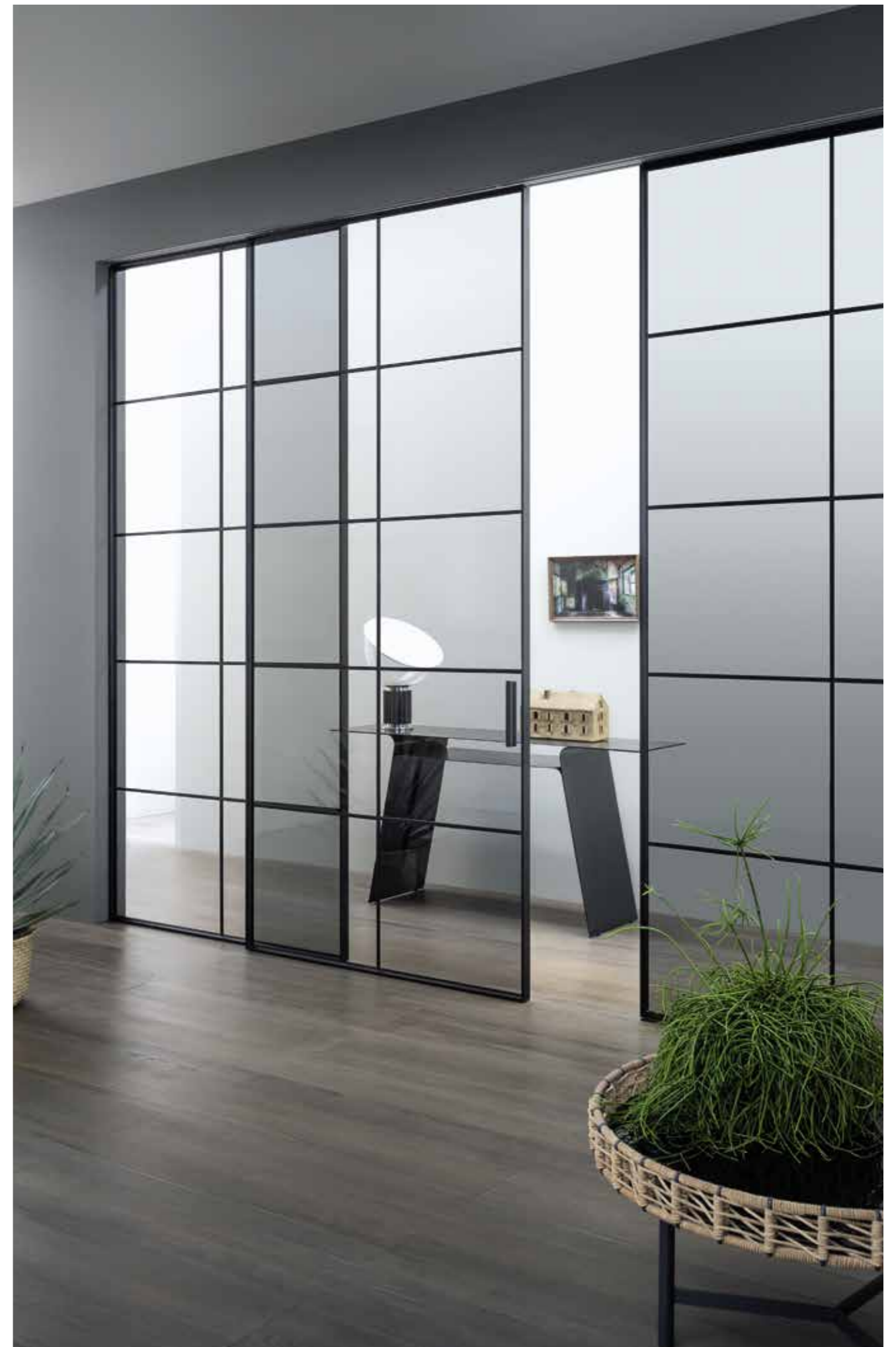



La purezza formale del disegno grafico del telaio e dei listelli di colore nero abbinati al vetro grigio trasparente.

The formal purity of the black frame and trim paired with grey transparent glass.

Shoin

Ispirata alle ampie e leggere superfici mobili della casa tradizionale giapponese, Shoin è un sistema ad uno o due binari, di pannelli scorrevoli, fissi e pivotanti, in vetro. Le lastre vivono all'interno di un sottile telaio in alluminio, a filo con il vetro sulla facciata esterna della composizione.

Inspired by the light and extensive mobile surfaces of the traditional Japanese house, Shoin is a system of one or two track, glass sliding or pivoting doors and fixed panels, designed to create walls. The panels are fixed within a slim aluminium frame, flush with the external side of the composition.





Shoin, composizione a due ante scorrevoli con telaio in alluminio bianco e vetro trasparente riflettente.

Shoin, a composition with two sliding doors, white aluminium frame and transparent reflective glass.





Parete divisoria realizzata con elementi scorrevoli e fissi Shoin in vetro Flutes grigio trasparente, profilo bronzo.

Partition wall composed of Shoin sliding and fixed elements in Flutes grey transparent glass, bronze profile.





Shoin, composizione a due ante fisse e due mobili. Il telaio in finitura bronzo è combinato con vetro Flutes grigio trasparente. La maniglia a incasso è inserita nel vetro.

Shoin, composition with two fixed and two sliding doors. The frame in a bronze finish is combined with Flutes grey transparent glass. The recessed handle is inserted directly into the glass.







La riuscita estetica di Shoin, anche nei sistemi più complessi e articolati, è il risultato di soluzioni funzionali.

Highly technological and functional solutions, even in the most complex system, are the key to the aesthetic success of Shoin.

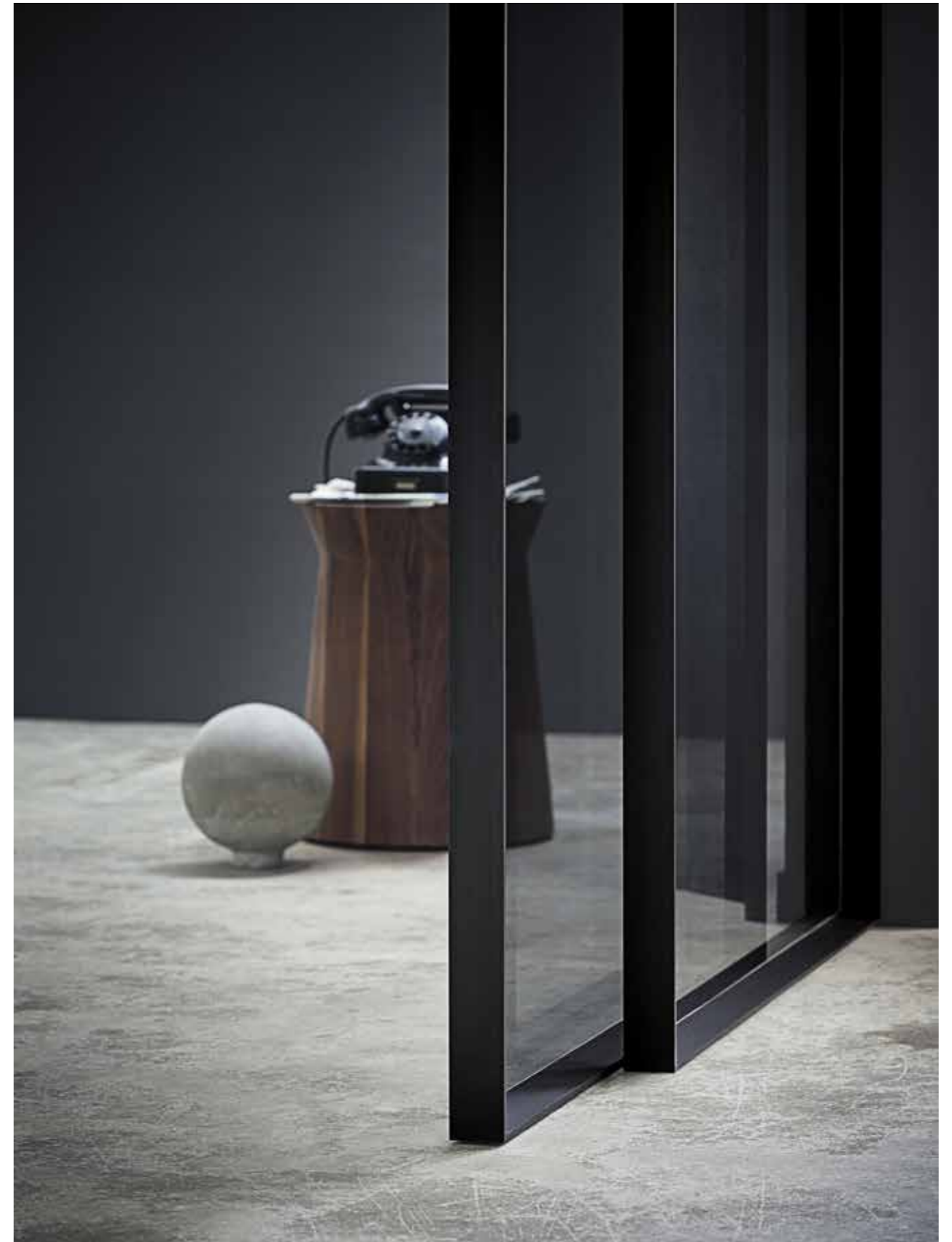

Shoin Pivot

Shoin Pivot è un sistema divisorio che si propone di delimitare gli ambienti con una presenza solida e, al contempo, quasi intangibile. Integrabile con pannelli apribili e fissi, l'eterea porta a bilico si distingue per la sua grande purezza formale.

Shoin Pivot is a partition system that aims to delimit environments with a solid and, at the same time, almost intangible presence. Integrable with opening or fixed panels, the ethereal pivoting door stands out for its great formal purity.



Shoin pivotante con finitura
in vetro, profilo nero.

Pivoting Shoin in glass,
black profile.





La presenza leggera di Shoin Pivot
crea ambienti nitidi e accoglienti,
scatole luminose attraversate
dalla luce.

The light presence of Shoin Pivot
creates well-defined and welcoming
environments, luminous boxes
traversed by light.

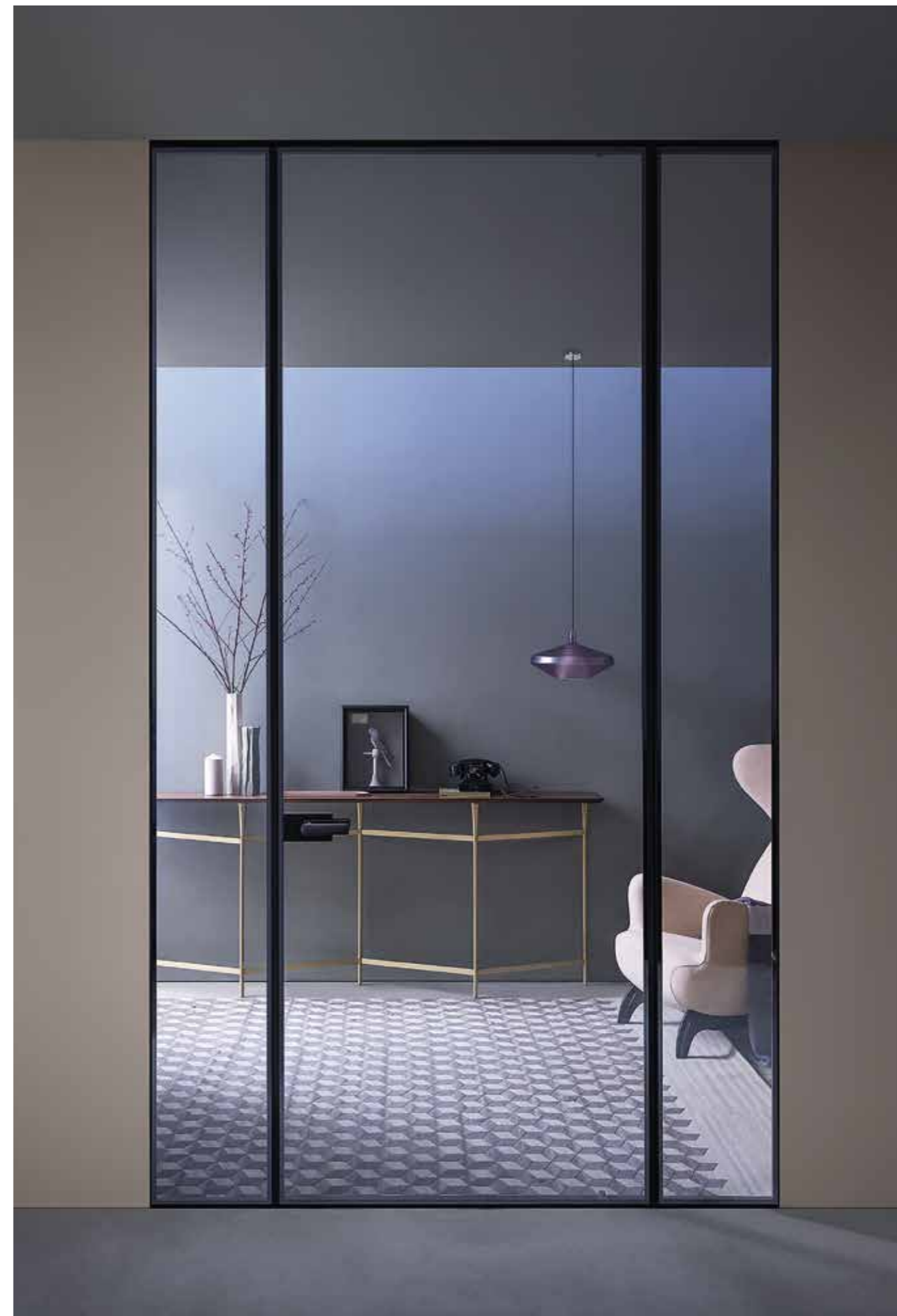

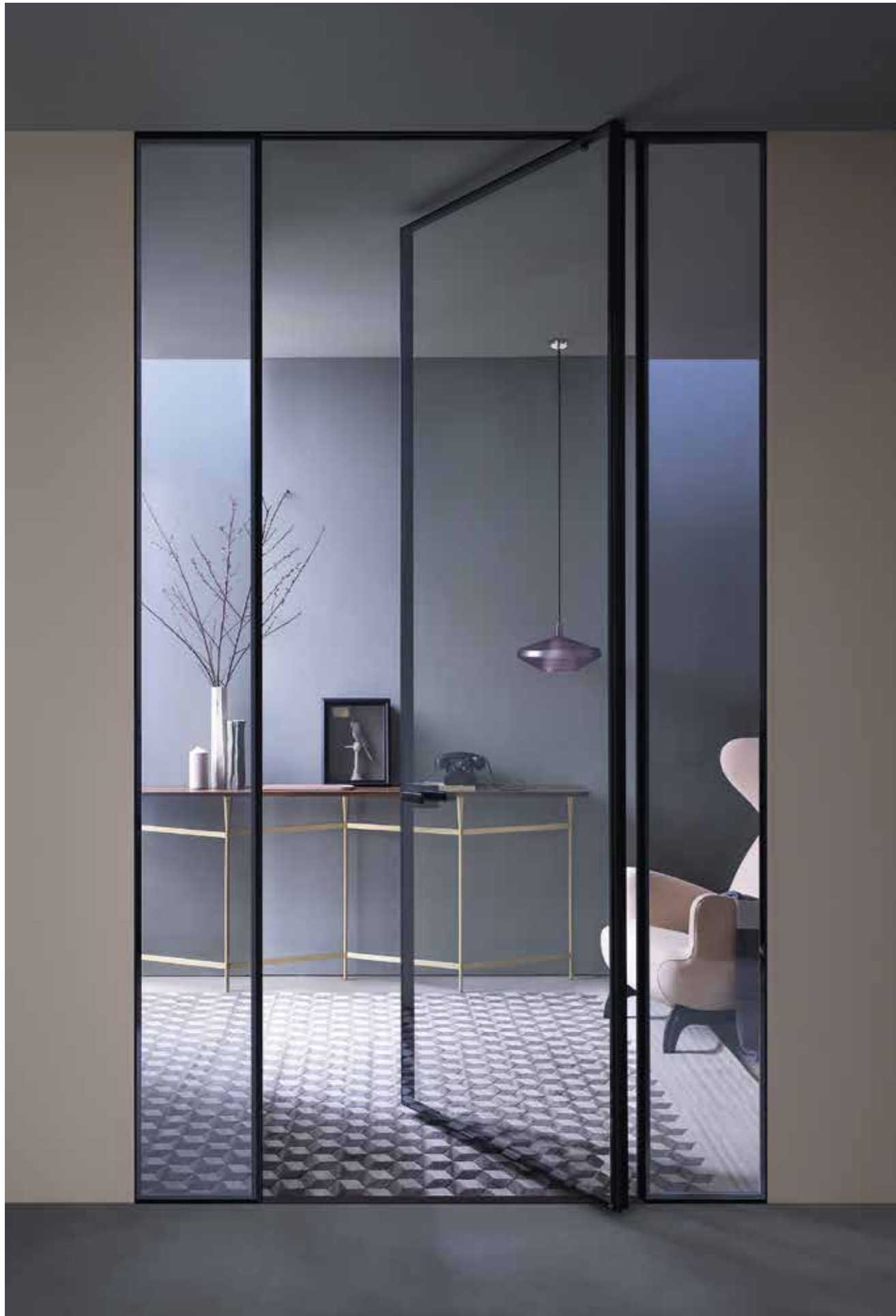

Inserita tra due pannelli fissi laterali, Shoin pivotante ha il vetro extrachiaro riflettente e il profilo in alluminio nero opaco.

Inserted between two fixed side panels, the pivoting Shoin has reflective extra-clear glass and a profile in matt black aluminum.

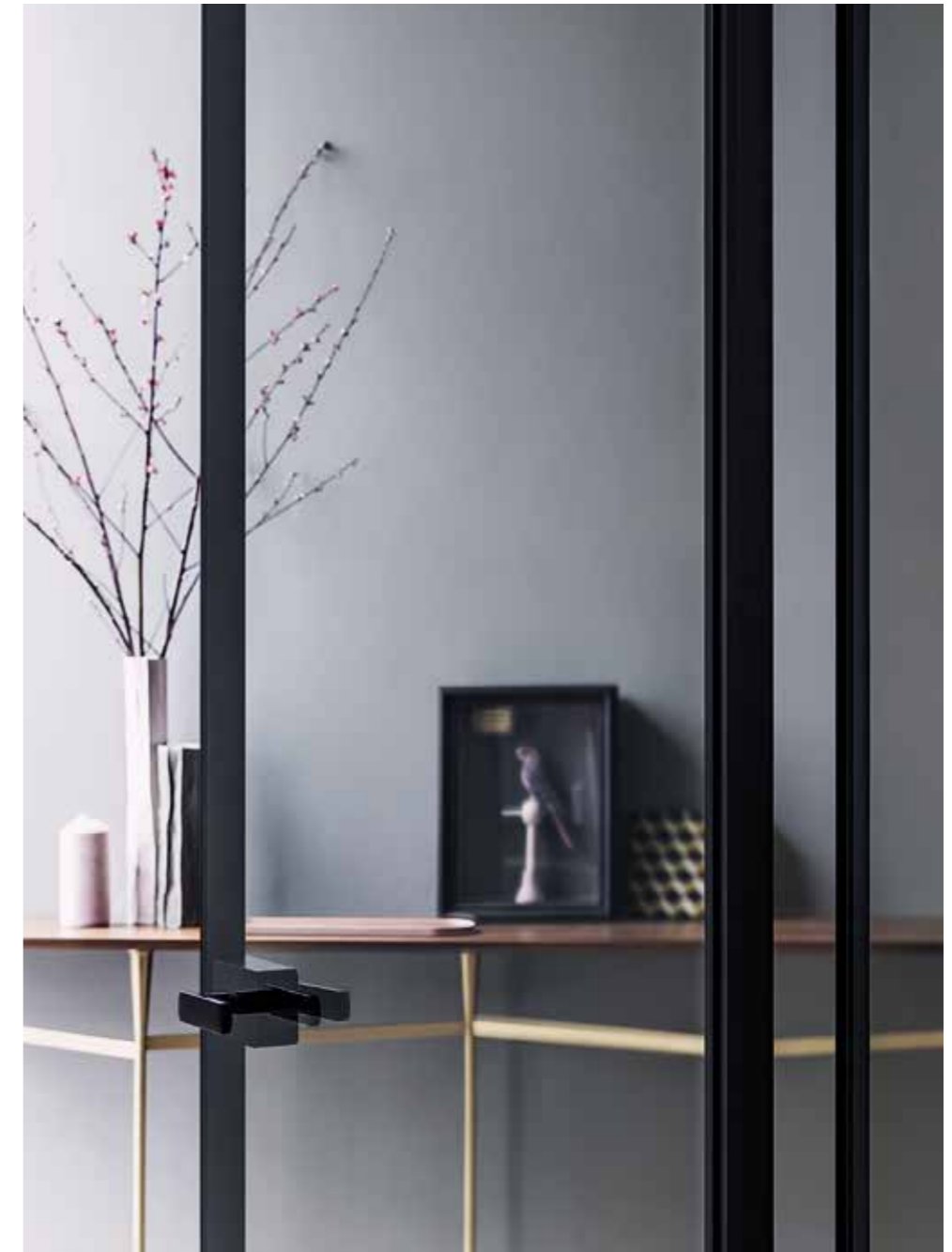

Koan

Unendo la luce di vetro e alluminio al calore del legno, Koan progettata da Kokai Studio, rappresenta la perfetta coesione tra tecnologia e tradizione. La combinazione di listelli verticali, che si alternano su lunghezze variabili, sottolinea il valore prezioso del pannello vetrato in grado di offrire un ritaglio scenografico dello spazio oltre la porta.

Koan, designed by Kokai Studio, combines the radiance of glass and metal finishes with the warmth of wood, creating a perfect cohesion of technology and tradition. The combination of vertical slats highlights the beauty of the glazed panel, offering a scenographic view of the space beyond the door.



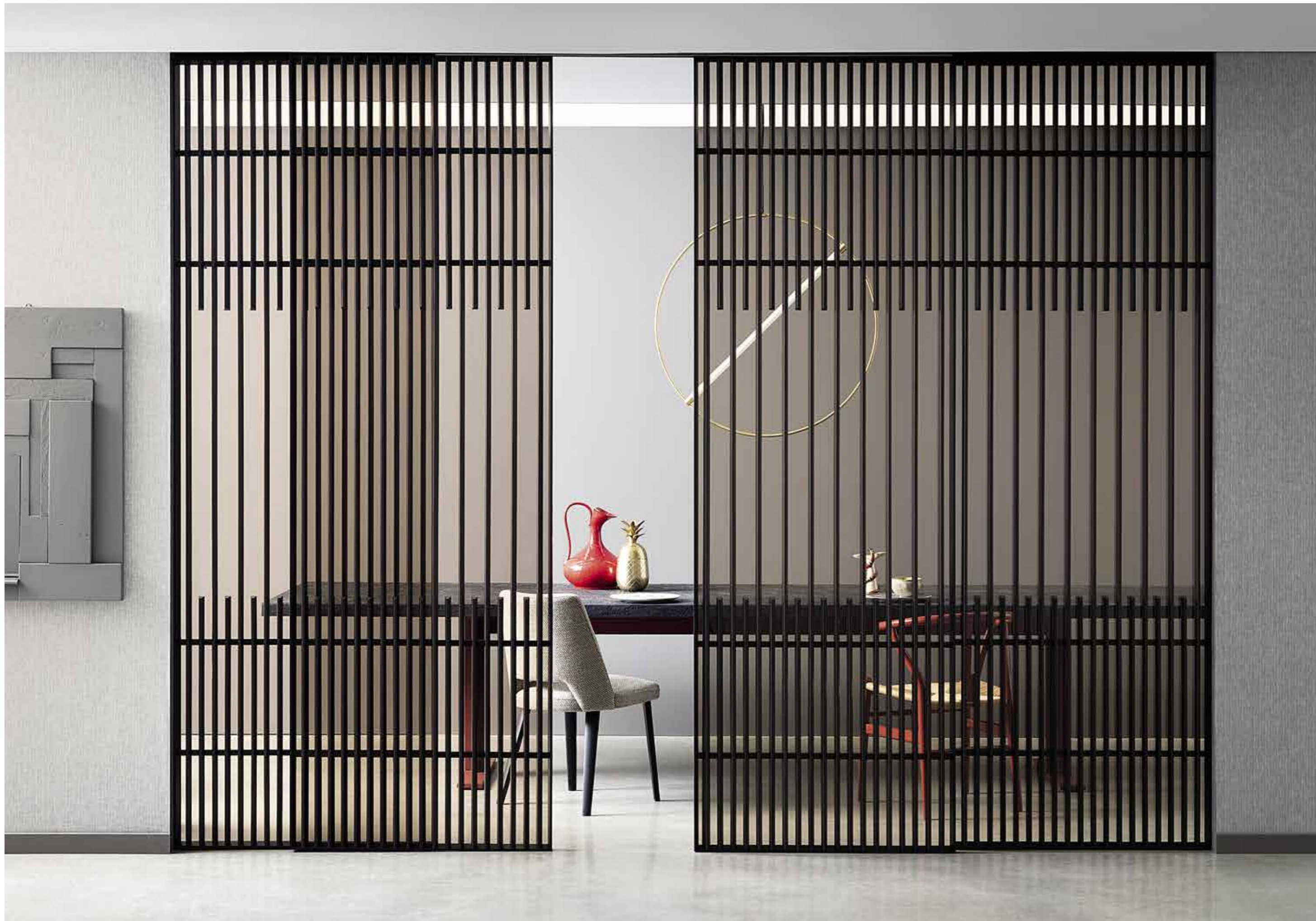



Riflessi caldi per questa
composizione a due ante
scorrevoli, con listelli in rovere
sabbia, profilo bronzo e vetro
grigio trasparente.

Warm reflections for the
composition with two
sliding doors, sand oak slats,
bronze profile and
transparent grey glass.



Riprendendo il leitmotiv dei listelli, la maniglia diviene un elemento verticale decorativo per un effetto di grande impatto visivo.

Taking up the leitmotiv of slats, the handle becomes a decorative vertical element to great visual effect.

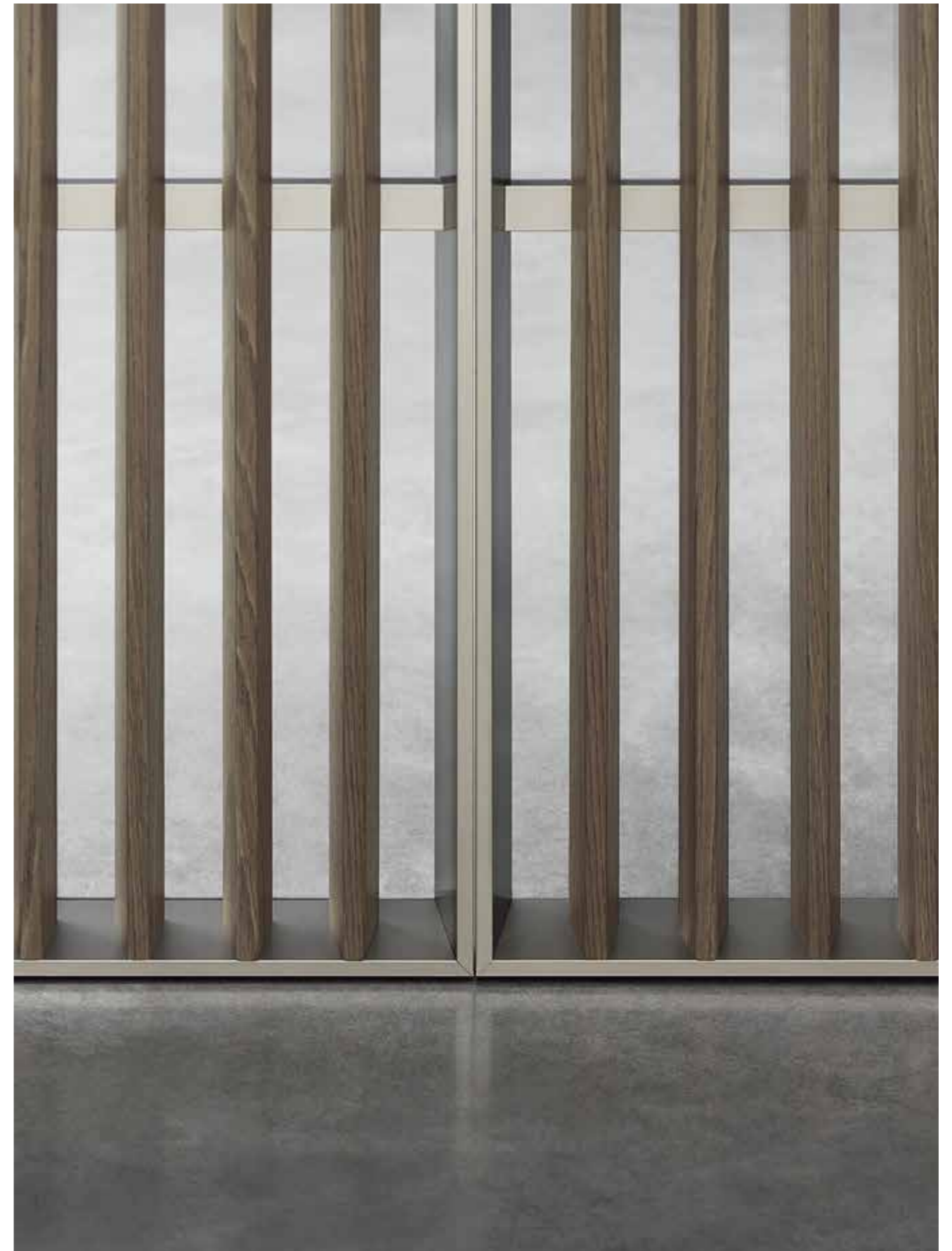

Koan Plus

Koan Plus, evoluzione dell'omonimo progetto disegnato da Kokai Studio, è un sistema configurabile composto da pannelli fissi e scorrevoli in vetro, alluminio e legno. Si ispira alle raffinate decorazioni delle tradizionali partizioni mobili cinesi reinterpretandole in chiave contemporanea.

Koan Plus, the evolution of the homonymous project designed by Kokai Studio, is a configurable system composed of fixed and sliding panels in glass aluminum and wood. It is inspired by the refined decorations of traditional Chinese mobile partitions, reinterpreted in a contemporary key.

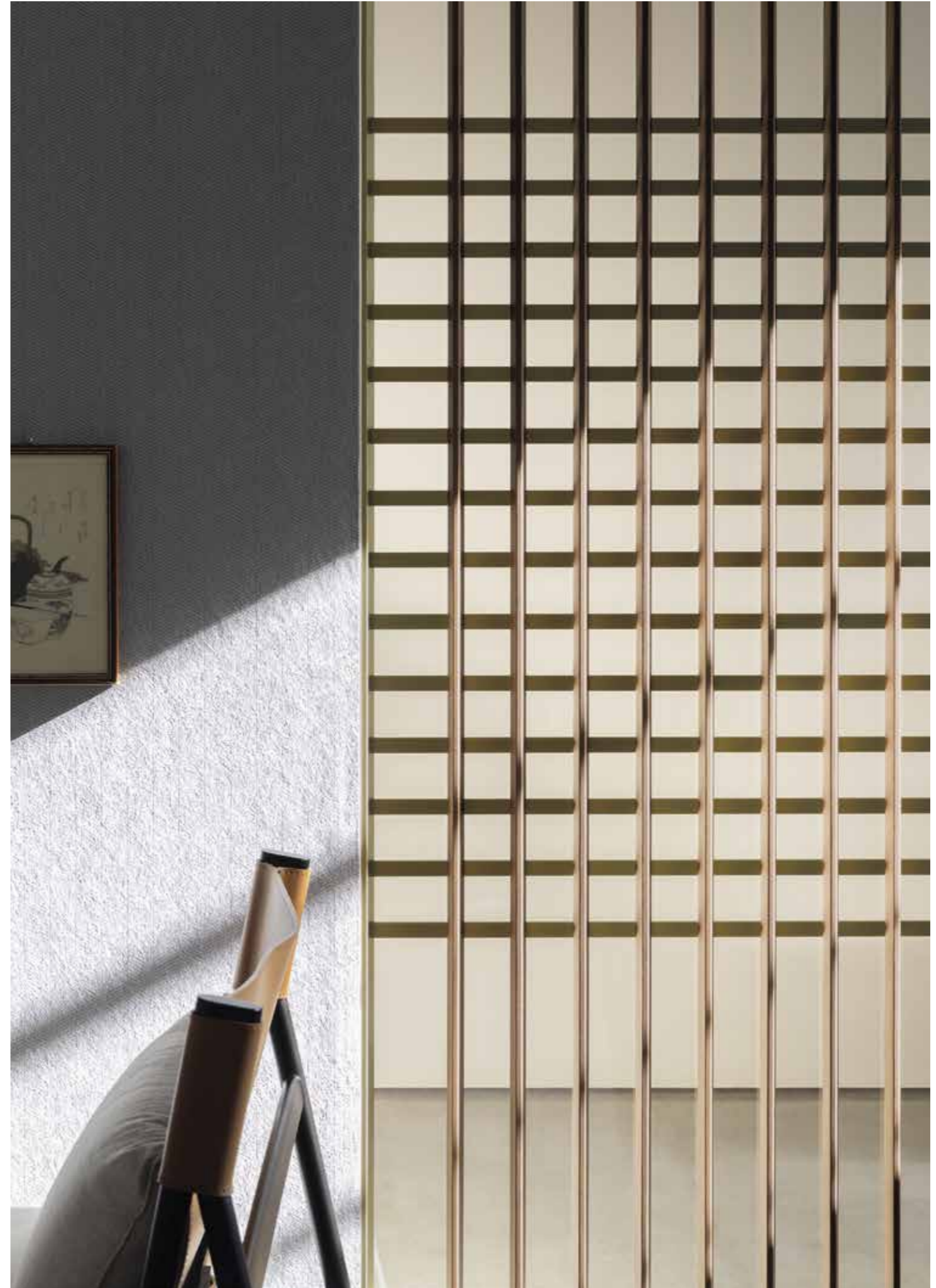



Segni netti e delicati e precise relazioni dimensionali e volumetriche realizzano un perfetto equilibrio visivo tra gli elementi di materiali diversi.

Clear and delicate lines and precise spatial and volumetric relationships create a perfect visual balance between the elements of different materials.



Il sistema geometrico di Koan Plus è una perfetta coesione tra tecnologia evoluta di produzione e tradizione figurativa di ispirazione orientale.

The geometric system of Koan Plus is a perfect cohesion between advanced production technology and the figurative tradition of oriental inspiration.

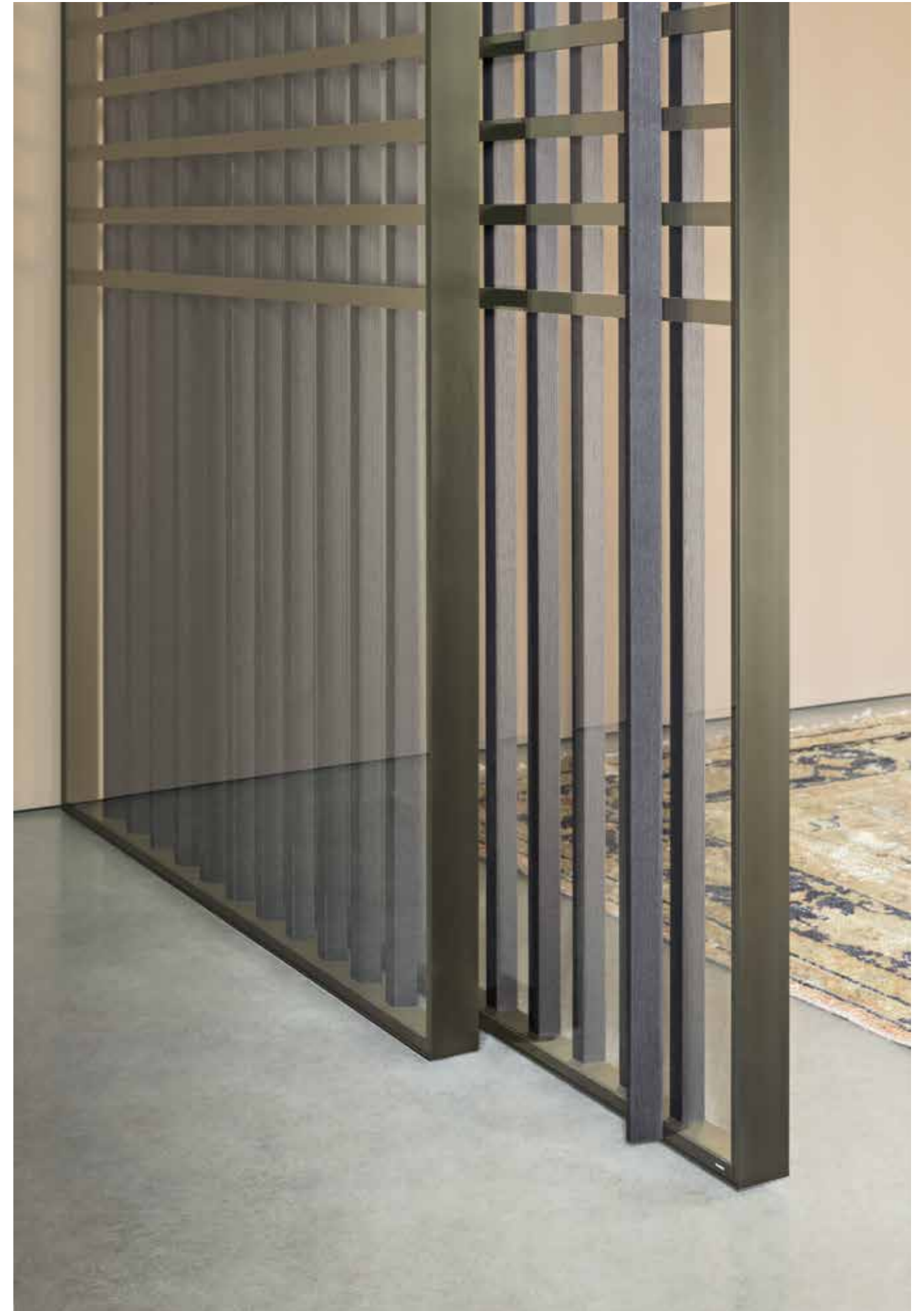

Il disegno grafico ed essenziale di Koan Plus unisce armonicamente la luce di vetro e alluminio con il calore del legno.

The linear and essential design of Koan Plus harmoniously integrates the luminosity of glass and aluminum with the warmth of wood.



Sliding 50

Duttile e versatile, il sistema di partizioni divisorie Sliding 50 è realizzato con pannelli scorrevoli di spessore 50 mm. Configurabile in molteplici versioni in essenza o laccato, si integra con estrema flessibilità nei diversi contesti architettonici.

The Sliding 50 partition system is both ductile and versatile and formed of 50 mm thick sliding panels. Configurable in a range of versions, both veneered and lacquered, it integrates with extreme flexibility in different architectural contexts.







La grande anta scorrevole
in rovere precomposto è una
presenza amichevole, una zona
di luce naturale e silenziosa.

The large sliding door in oak
veneer is a friendly presence,
an area of natural light and silence.



Una bellezza materica e naturale per l'anta scorrevole in finitura Matrix, sottolineata dall'armonia della pannellatura liscia in noce canaletto.

A materic and natural beauty for the sliding panel in Matrix finish, accentuated by the harmony of the wall cladding in Canaletto walnut.



Rasomuro 55 System

[84 - 149]

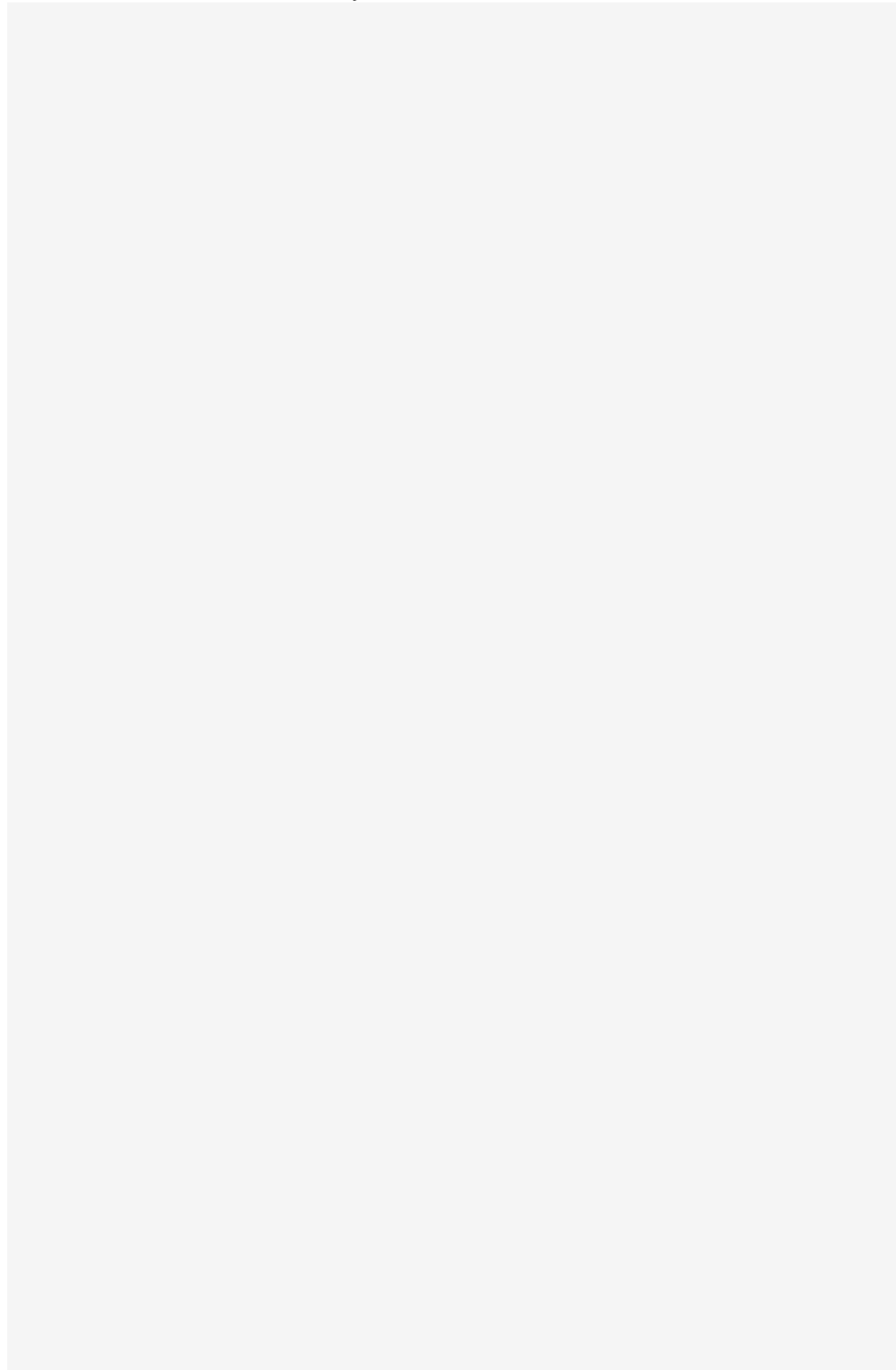

*É la naturale evoluzione del modello storico Rasomuro.
Perfettamente integrata nella struttura architettonica,
la porta “che non c’è” ha le cerniere a totale scomparsa,
lo stipite invisibile in alluminio e la capacità di integrarsi
alla parete con mimetismo perfetto.*

*This is the natural evolution of the celebrated Rasomuro.
Perfectly integrated into the architectural structure,
the door “which isn’t there” features hinges
that are completely hidden, an invisible aluminium
jamb and the ability to integrate with the wall
with perfect mimicry.*

Rasomuro 55s

Elemento architettonico di transito tra un ambiente e l'altro, la porta integrata alla parete ha un grado di essenzialità visiva e concettuale estrema. Il design è quasi immateriale, per l'eleganza della superficie continua senza alcun dettaglio strutturale a vista.

An architectural element of transition from one space to another, the door integrates into the wall and is particularly minimal in look and radical in concept. The design becomes almost ethereal in the elegance of its seamless surfaces that feature no visible structural detail.

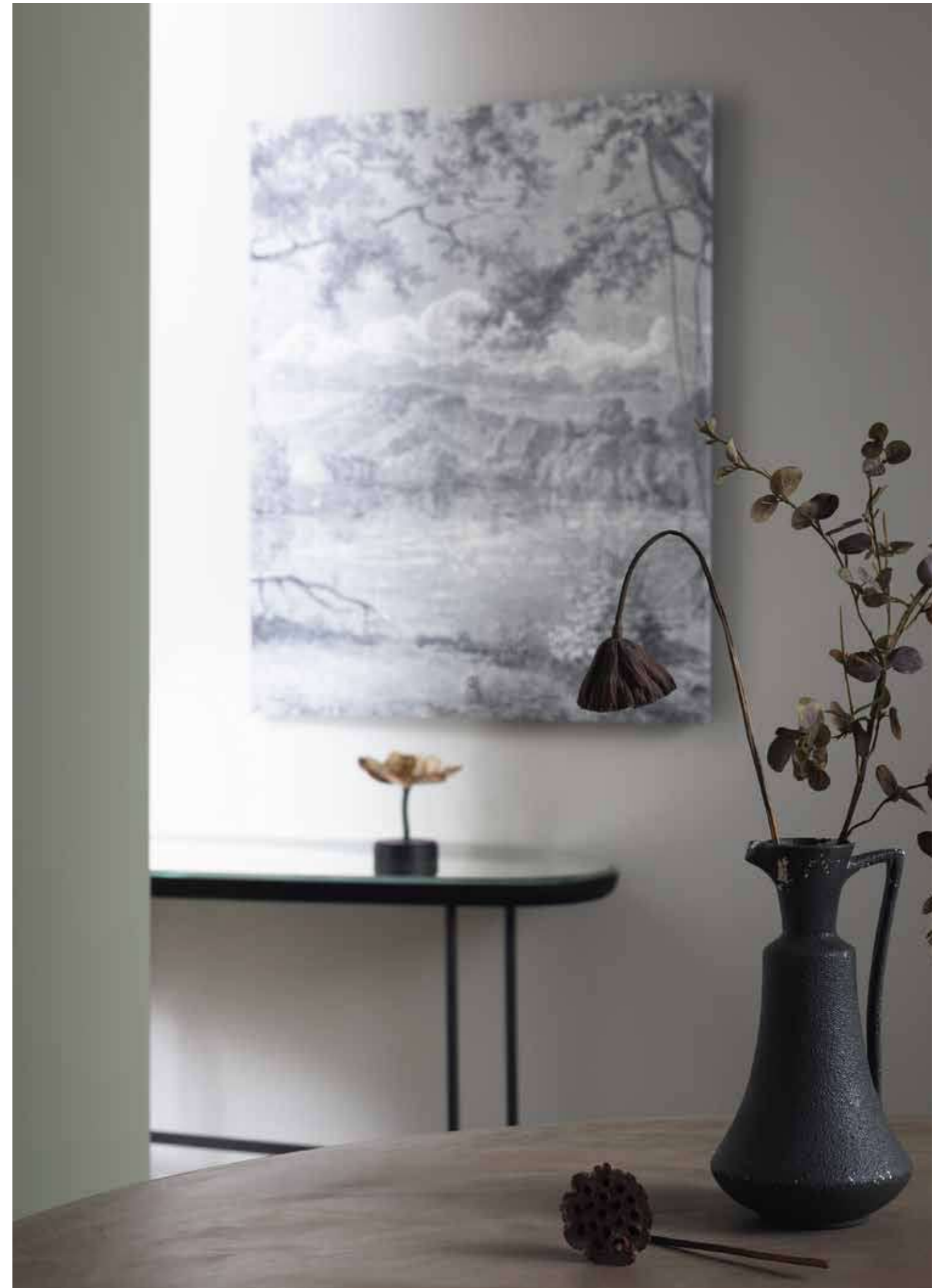



Il disegno grafico creato dalla porta Rasomuro 55s in bianco opaco in combinazione cromatica con la parete di diverso colore.

The delineated design created by the Rasomuro 55s door in matt white establishes a chromatic combination with the wall of a different color.







Grazie alle cerniere completamente a scomparsa, al forte spessore e allo stipite invisibile in alluminio, la porta integrata nella parete si mimetizza nell'ambiente.

Thanks to the completely hidden hinges, the pronounced thickness and the invisible aluminium jamb, the door integrates with the wall and blends into the surrounding environment.





Rasoline 55s

Perfettamente integrata con la parete e l'architettura circostante, Rasoline 55s segna il passaggio da un ambiente all'altro indossando finiture diverse. Due superfici che dialogano con gli spazi circostanti, assecondandone con eleganza le caratteristiche. Le contiene un essenziale bordo metallico in funzione strutturale e decorativa.

Perfectly integrated with the wall and the surrounding architecture, Rasoline 55s marks the transition from one room to another with different finishes. Two surfaces that dialogue with the surrounding spaces, complementing their characteristics with elegance. The elemental metal edging, available in various finishes, is both structural and decorative.







L'anta di Rasoline 55s da un lato è in rovere precomposto, dall'altro grezza verniciata come il muro. Lo stipite e il bordo metallico color bronzo ben si accordano alla qualità cromatica del legno.

One side of the Rasoline 55s door is oak veneered, while the other is left unfinished ready to be painted in the same color as the wall. The bronze colored metal jamb and edging coordinate with the color of the wood.



Rasotouch 55s

Rasotouch è il modello più invisibile della famiglia, creato per scomparire completamente nello spazio circostante. Tocco di perfetta eleganza, la maniglia a scomparsa: un taglio verticale che corre lungo l'anta con la rapidità del più semplice fra i segni: una linea. Design Cairoli & Donzelli.

Rasotouch is the most invisible model of the family, specifically created to disappear completely into the surrounding space. The recessed handle is a touch of perfect elegance: a vertical cut runs along the door in the simplest of forms - a straight line. Design Cairoli & Donzelli.





Finitura in laccato opaco bianco:
la porta diventa un elemento
architettonico vero e proprio
che concorre a rendere lo spazio
armonico e omogeneo.

Finished in matt white lacquer:
the door becomes a true
architectural element which
contributes to making the space
both uniform and harmonious.

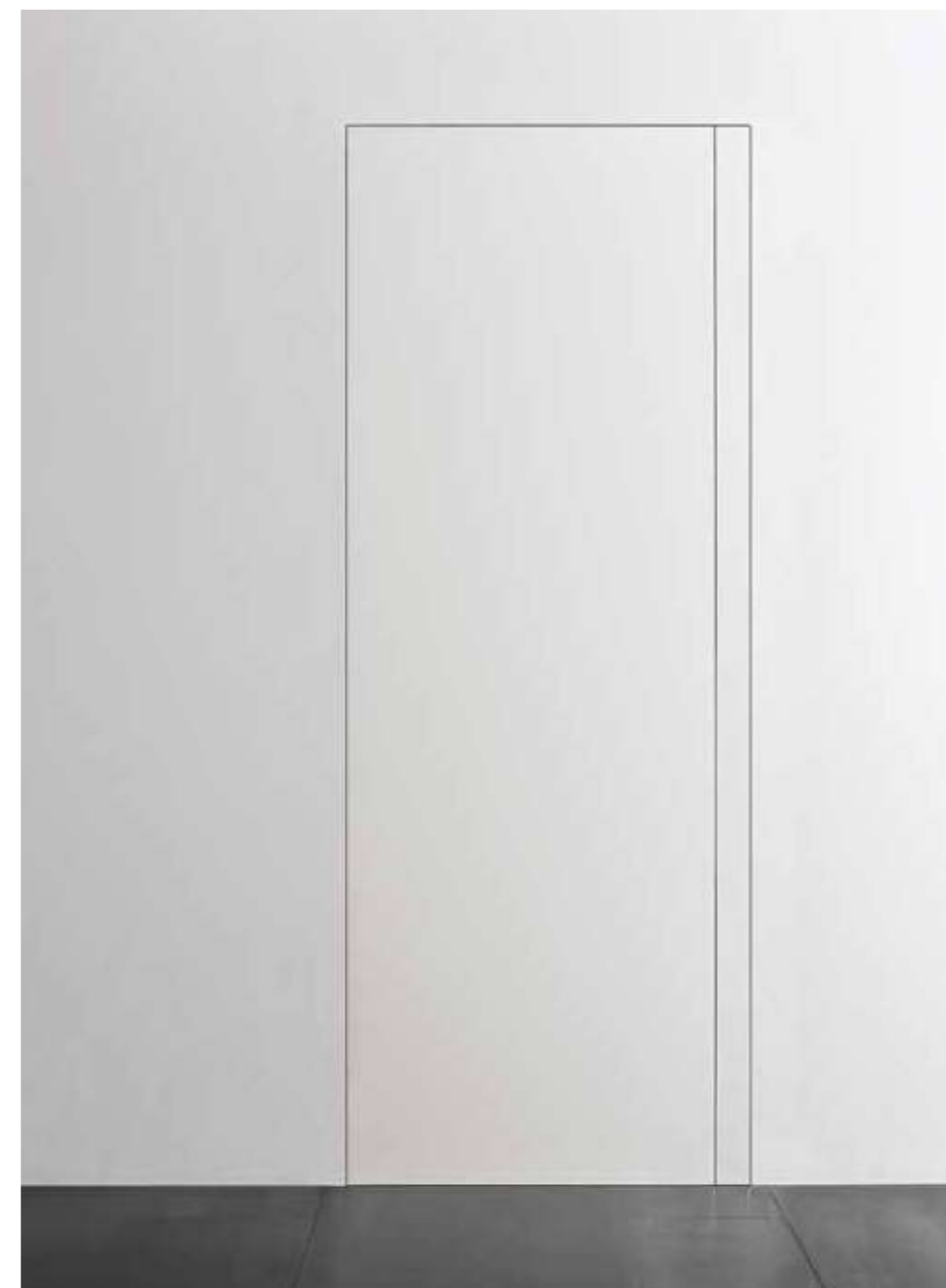



Pratica e funzionale, la maniglia a scomparsa garantisce una presa facile e gradevole.

Practical and efficient, the recessed handle provides an easy and comfortable grip.



Rasovetro 55s

Rasovetro nasce da Rasomuro e della famiglia ha tutte le caratteristiche, come le cerniere a scomparsa e lo stipite in alluminio.

Esteticamente, invece, sviluppa la propria originalità grazie al vetro, materiale pulito per eccellenza, e alle sue prerogative uniche: trasparenza, luminosità, leggerezza.

Rasovetro derives from Rasomuro and shares all its characteristics, such as the concealed hinges and the aluminium jamb. However, it demonstrates its own aesthetic originality thanks to the glass, the purest of materials, and its unique features of transparency, luminosity and lightness.





Anta in vetro retrolaccato:
una presenza capace di accendere
lo spazio di sofisticati riflessi.

Door in back-painted glass:
capable of illuminating a space
with sophisticated reflections.





Trasparenza, luminosità,
leggerezza estrema sono
le prerogative della porta
nella versione con l'anta
in vetro e profilo di alluminio.

Transparency, brightness
and extreme lightness are
the particular qualities of this
door in the glass version with
aluminium profile.

Edge

La collezione di porte Edge, disegnata da Marco Piva, nasce dal desiderio di plasmare un oggetto solitamente "piatto", creando un effetto volumetrico mirato a donargli una nuova importanza visiva, senza venir meno alla sua funzionalità. Edge è un incontro di geometrie, volumi e superfici che donano al "passaggio" tra ambienti una nuova enfasi.

Edge is the new collection of doors designed by Marco Piva for Lualdi, born from a desire to give a three-dimensional form to an object that is usually "flat", creating a feeling of volume that confers a new visual significance without affecting functionality. Edge is a meeting of geometries, volumes and surfaces that play on visual perception and transform the door, a "connecting" element between home and office environments, into a new exponent of the living area.



Il taglio simmetrico a 45 gradi sui quattro lati di Edge crea un effetto prospettico elegante e raffinato. Nell'immagine la porta è nella versione laccato opaco bianco gesso.

The symmetrical, 45 degree camber around the four sides of Edge creates a refined and elegant perspective. The picture shows the door in the matt, chalk-white lacquered version.





Dettaglio profilatura del pannello frontale di Edge, un delicato gioco di luci e ombre sulla superficie della porta.

Detail of the profile of the Edge front panel, a subtle play of light and shadow on the surfaces of the door.



Raso USA

A filo parete, con le cerniere a totale scomparsa, il forte spessore e lo stipite a vista, Raso USA ha le stesse caratteristiche tecniche strutturali di Rasomuro 55s, ma ha sempre il profilo di alluminio a vista che diventa elemento grafico e decorativo della porta.

Flush with the wall, with the hinges completely hidden, the pronounced thickness and the visible jamb, Raso USA has the same structural technical characteristics of Rasomuro 55s while maintaining the visible aluminium profile that becomes a defining and decorative element of the door.

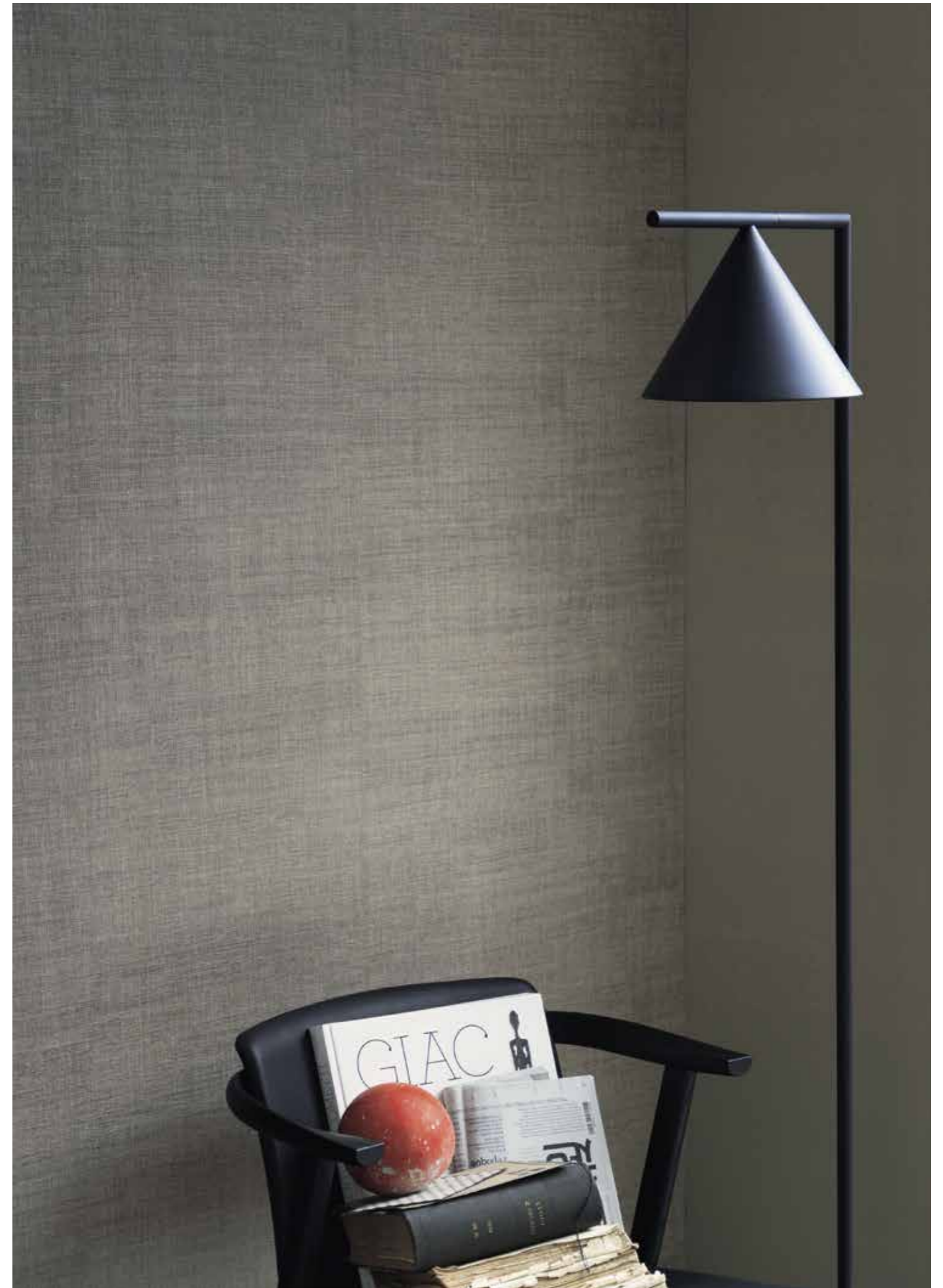

Il profilo di alluminio a vista
in versione di colore nero delinea
il perimetro della porta a filo parete
e ne sottolinea la superficie.

The black version of the visible
profile outlines the perimeter of
the door that is flush with the wall
and accentuates the surface.





Il profilo a vista della porta
Raso USA in alluminio,
in finitura di colore nero.

The visible profile of the
Raso USA door in aluminium
with a black finish.

Compass 55

Perfettamente allineata, dotata di anta pivotante, Compass 55 ha l'aspetto di una quinta ampia e silenziosa, capace di mettere in comunicazione gli spazi con leggerezza.

Perfectly aligned and equipped with pivoting door, Compass 55 can be compared to a large, silent stage curtain, enabling areas to communicate with lightness.







Lo spessore dell'anta pivotante di Compass 55, qui in versione nero fossile.

The thickness of the pivoting Compass 55 door, here in black fossil version.







L'ampiezza della quinta teatrale
pivotante di Compass 55
ne accentua l'aspetto scenico
di divisorio spaziale.

The expanse of the pivoting
theatrical backdrop of
Compass 55 accentuates the
scenic aspect of the spatial divider.

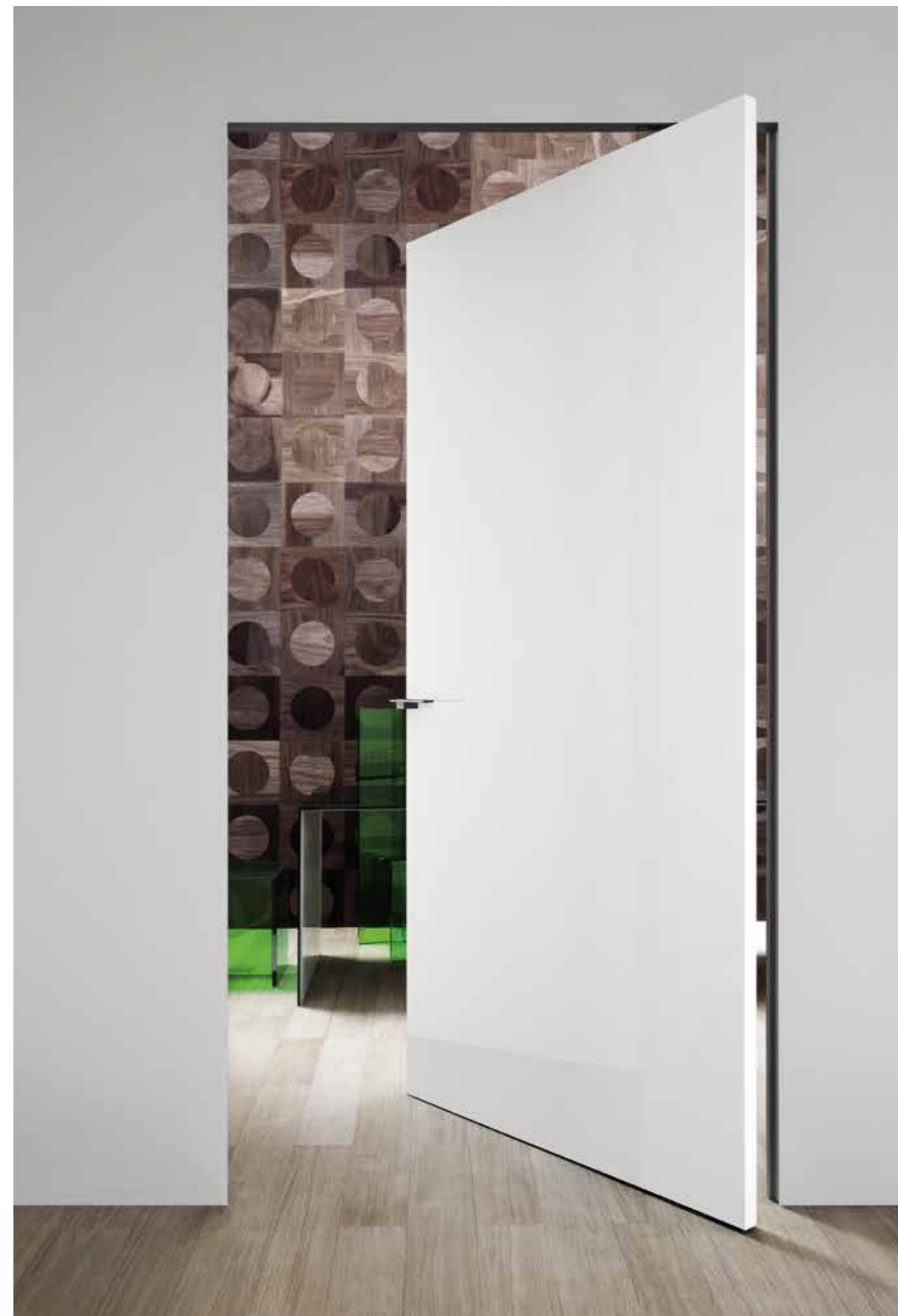

Il calore e la vita del legno vengono resi palpabili dal volume nitido dell'anta pivotante, i cui dettagli scolpiscono delicatamente la parete.

The warmth and life of wood are made palpable by the clear-cut volume of this pivoting door, whose details delicately sculpt the wall.



L'anta pivotante Compass 55 con finitura Matrix creata dall'accostamento di tre intagli diversi e profilo in bronzo.

The pivoting door of the Compass 55 with a Matrix finish created by the combination of three different forms of fretworking and a bronze profile.

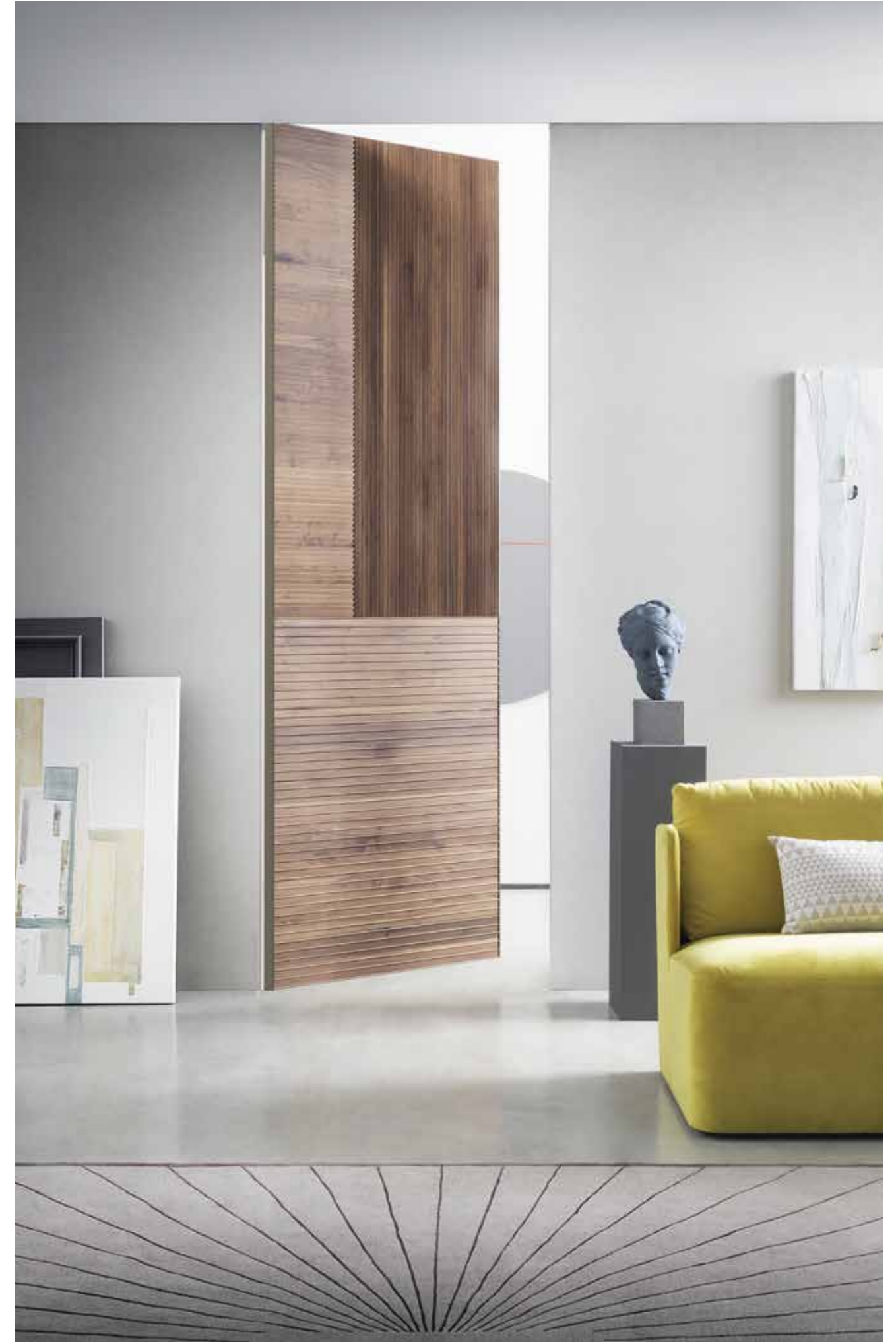



I tre diversi pattern grafici della finitura Matrix accentuano la raffinatezza della lavorazione del legno massello.

The three different patterns of the Matrix finish accentuate the refinement of the woodworking.



Sliding Pocket

Per uno spazio più fluido, la porta scorrevole interno muro a scomparsa con l'essenziale maniglia a incasso, mette in comunicazione gli ambienti eliminando la presenza visiva dello stipite e l'ingombro dell'anta.

For a more fluid space, the sliding pocket door with the minimalist recessed handle connects the rooms by eliminating the visual presence of the jamb and the encumbrance of the door.

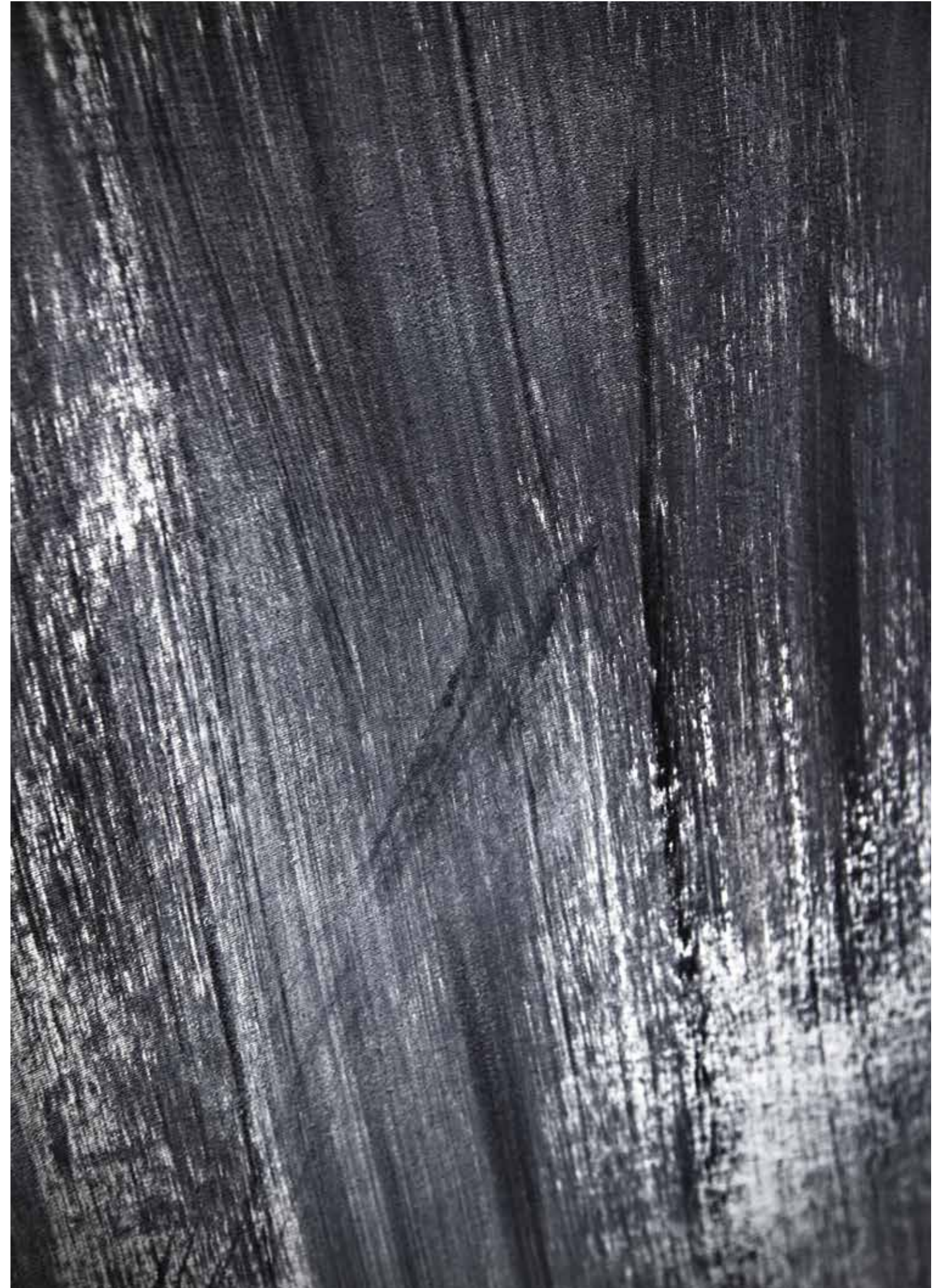

Elegante e raffinata, la porta scorrevole interna in finitura rovere color moka.

Elegant and refined, the sliding pocket door in a mocha-colored oak finish.

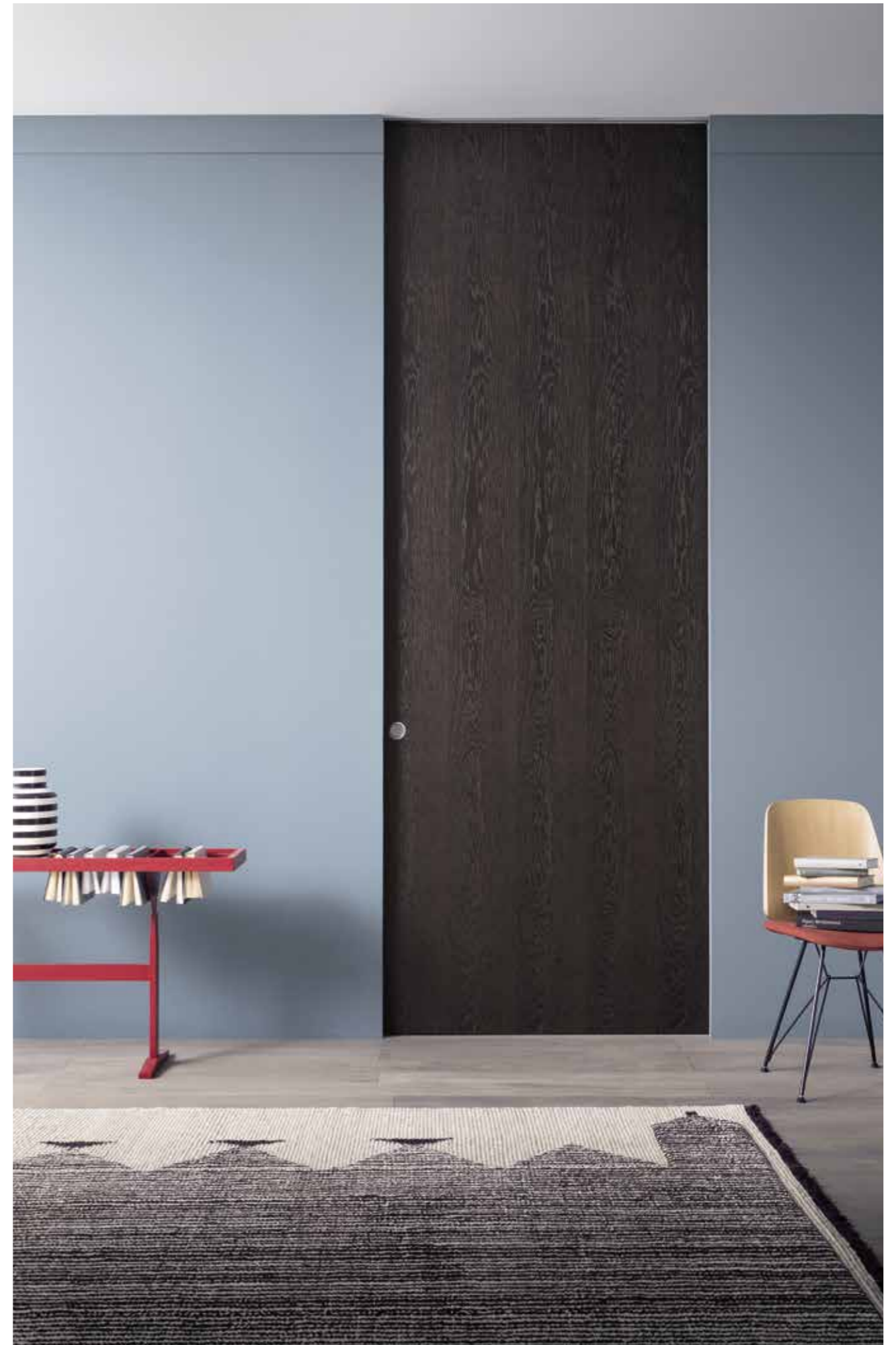



La porta scorrevole all'interno del muro è essenziale per la sua purezza formale.

The sliding pocket door has an essential and formal purity.



Doors

[150 - 247]

Porte a battente di tradizionale memoria storica e porte di design contemporaneo, dai linguaggi espressivi diversi, ma uniti dal comune denominatore dell'essenzialità visiva del loro disegno, in sintonia e continuità con i più eterogenei stili dell'architettura degli interni.

Hinged doors of historical tradition and doors of contemporary design, each with different expressive languages but united by the common denominator of their visually minimalist design, sit in harmony and continuity with the most diverse styles of interior architecture.

Altaj

Purezza formale e un sorprendente effetto visivo tridimensionale di profondità sono le peculiarità della porta Altaj disegnata da SBGA Blengini Ghirardelli. Il concept di Altaj va oltre il minimalismo della porta a filo muro che mira a scomparire nella parete, con una innovativa e inconfondibile interpretazione. Il dettaglio che caratterizza il progetto è il profilo metallico che incornicia l'anta portandola in aggetto. La simmetria del bordo e l'assenza di battuta diventa elemento decorativo peculiare, creando due piani di lettura grazie al gioco di ombre con il telaio a filo parete. Pivottante, con il telaio in alluminio, Altaj ha nuove finiture di pregio come le texture in legno bicolore Chocolat e l'intreccio in pelle.

Formal purity and a surprising three-dimensional effect that confers a sense of depth are the distinguishing features of the Altaj door designed by SBGA Blengini Ghirardelli. The concept behind Altaj goes beyond the minimalism of the flush door that almost disappears into the wall, with an interpretation that is innovative and unmistakable.

The distinguishing detail of the project is the metal profile that frames the door and projects it forward. The symmetry of the edge and the absence of a striker become very particular decorative elements, creating two different appearances thanks to the play of shadows with the flush-to-wall frame. Pivoting, with an aluminium frame, Altaj comes with new refined finishes such as the two-tone Chocolat wood textures and woven leather.

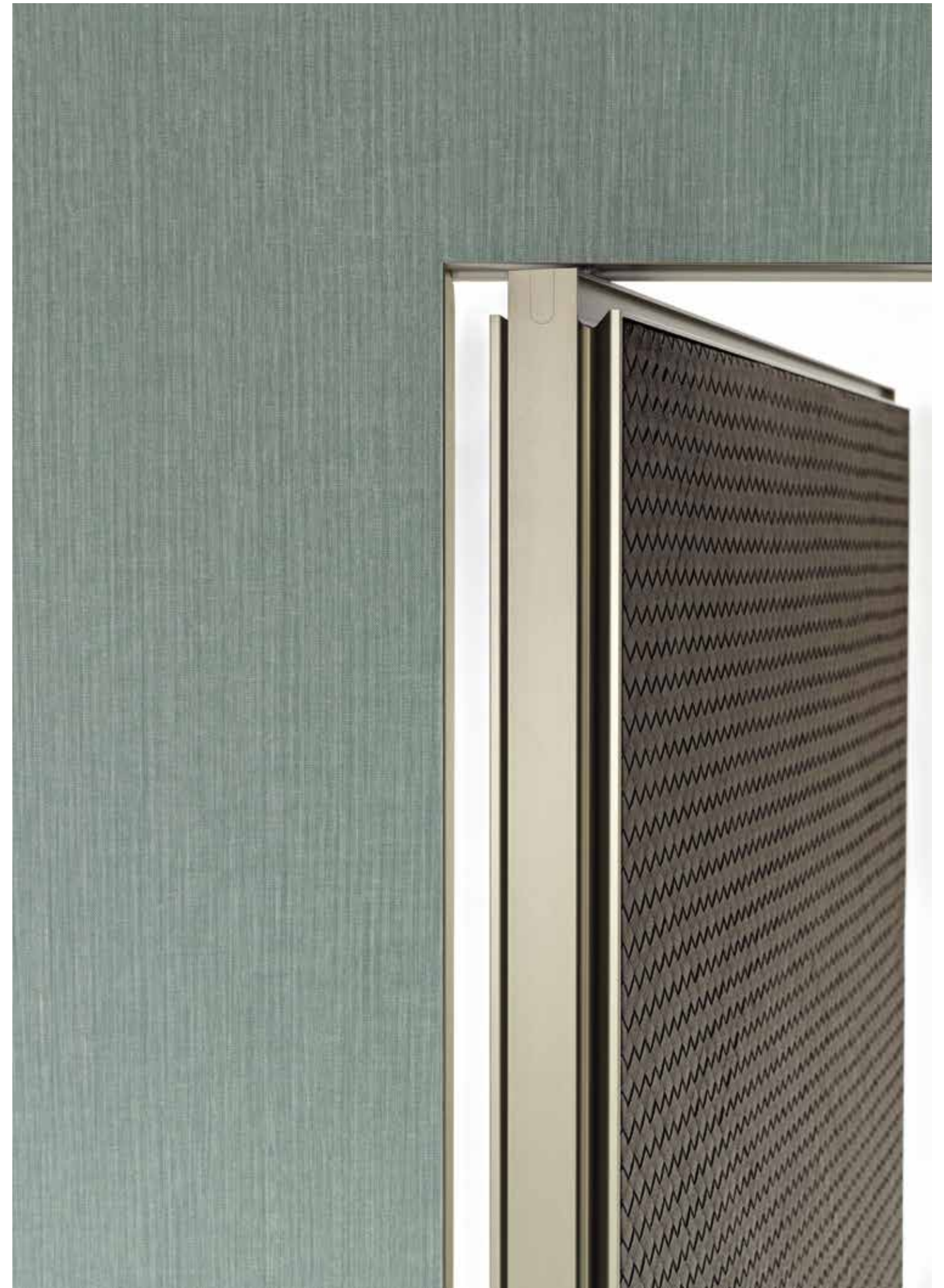



L'elegante versione di Altaj
con i profili bronzo e l'anta
in pelle intrecciata.

The elegant version of Altaj
with bronze profiles and door
in woven leather.

Materica ed elegante,
la sofisticata versione di Altaj
con l'anta in pelle intrecciata.

Materic and elegant,
the sophisticated version of Altaj
with door in woven leather.

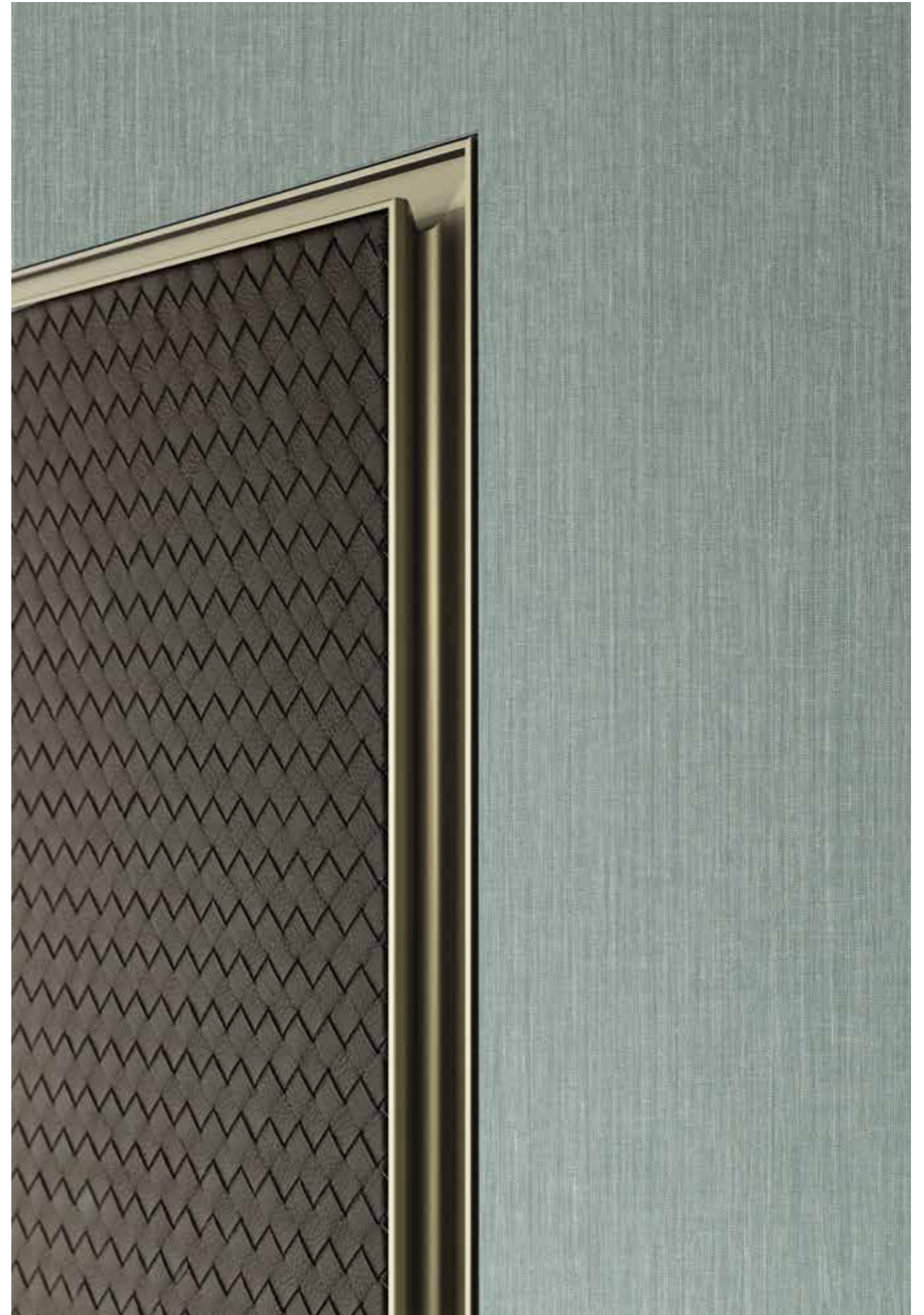



Il bordo che incornicia la superficie dell'anta portandola in aggetto crea più piani di lettura della porta.

The edge framing the surface of the door and projecting it forward gives the door different appearances depending on the viewing angle.





Altaj con profilo in alluminio bronzo e anta finitura Chocolat R in rovere grigio su nero fossile.

Altaj with the bronze aluminium profile and the Chocolat R finish door in grey oak on fossil black.

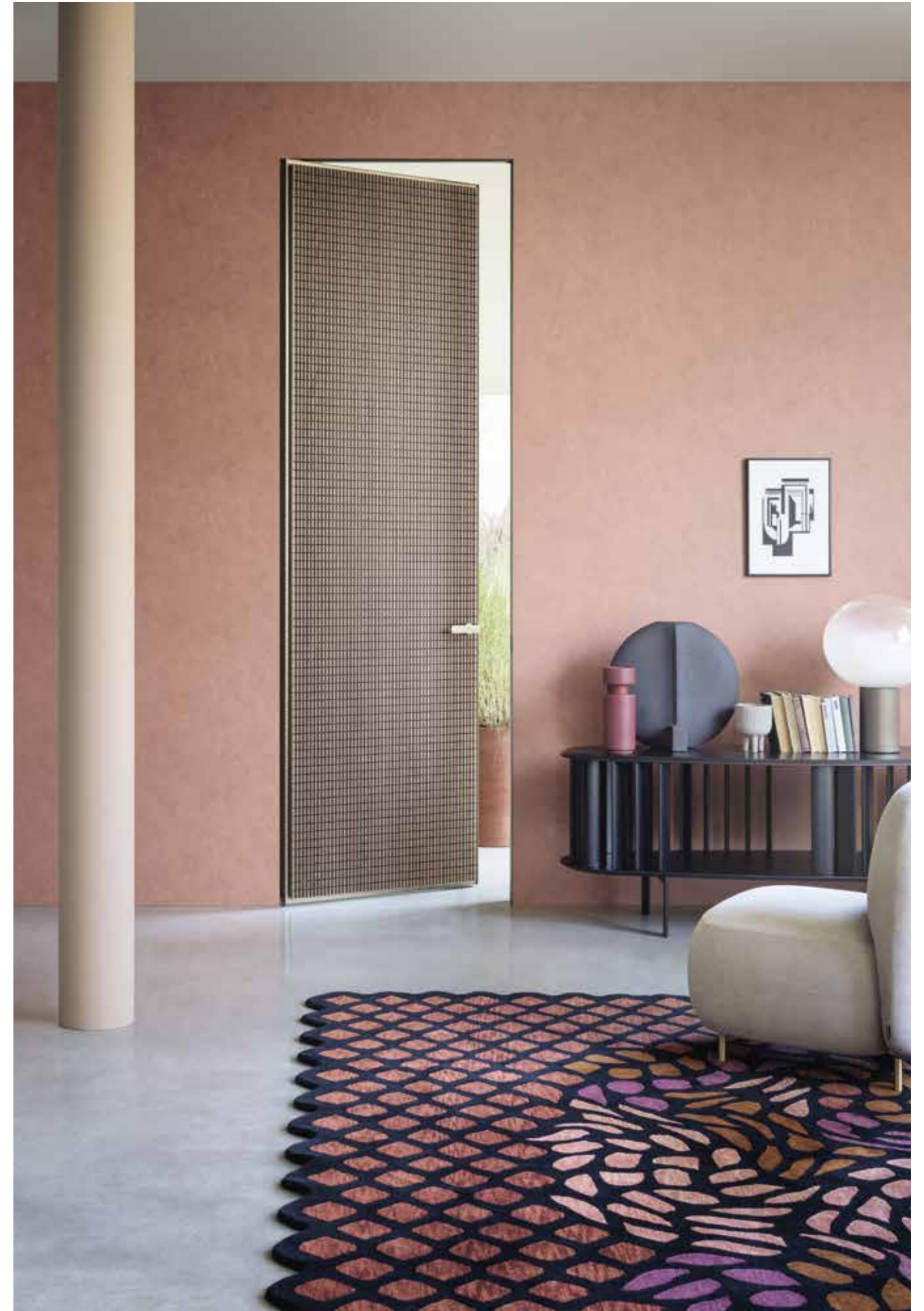



Ying

La collezione di porte Ying, disegnata da Steve Leung, è un affascinante mix tra la tradizionale tecnica cinese della lavorazione del legno e la moderna maestria industriale italiana. È caratterizzata dalla base scolpita in legno scuro e dal telaio con dettagli delicati che traggono ispirazione dall'antica arte cinese "sǔn mǎo", che veniva utilizzata per creare manufatti eleganti e senza tempo. La parte superiore consente la personalizzazione su misura della porta attraverso un'ampia selezione di colori e materiali, dalle lacche alla pelle, per integrarsi con armonia a diversi stili di arredo.

Designed by Steve Leung, the Ying door collection is an enchanting mix of traditional Chinese woodworking techniques and modern Italian industrial craftsmanship. It is distinguished by the sculpted base in dark wood and the delicate details of the frame that draw inspiration from the ancient Chinese art of "sǔn mǎo", used to create elegant and timeless artifacts. The upper part allows the door to be customized with a wide selection of colours and materials, including lacquers and leather, to integrate harmoniously with different furnishing styles.

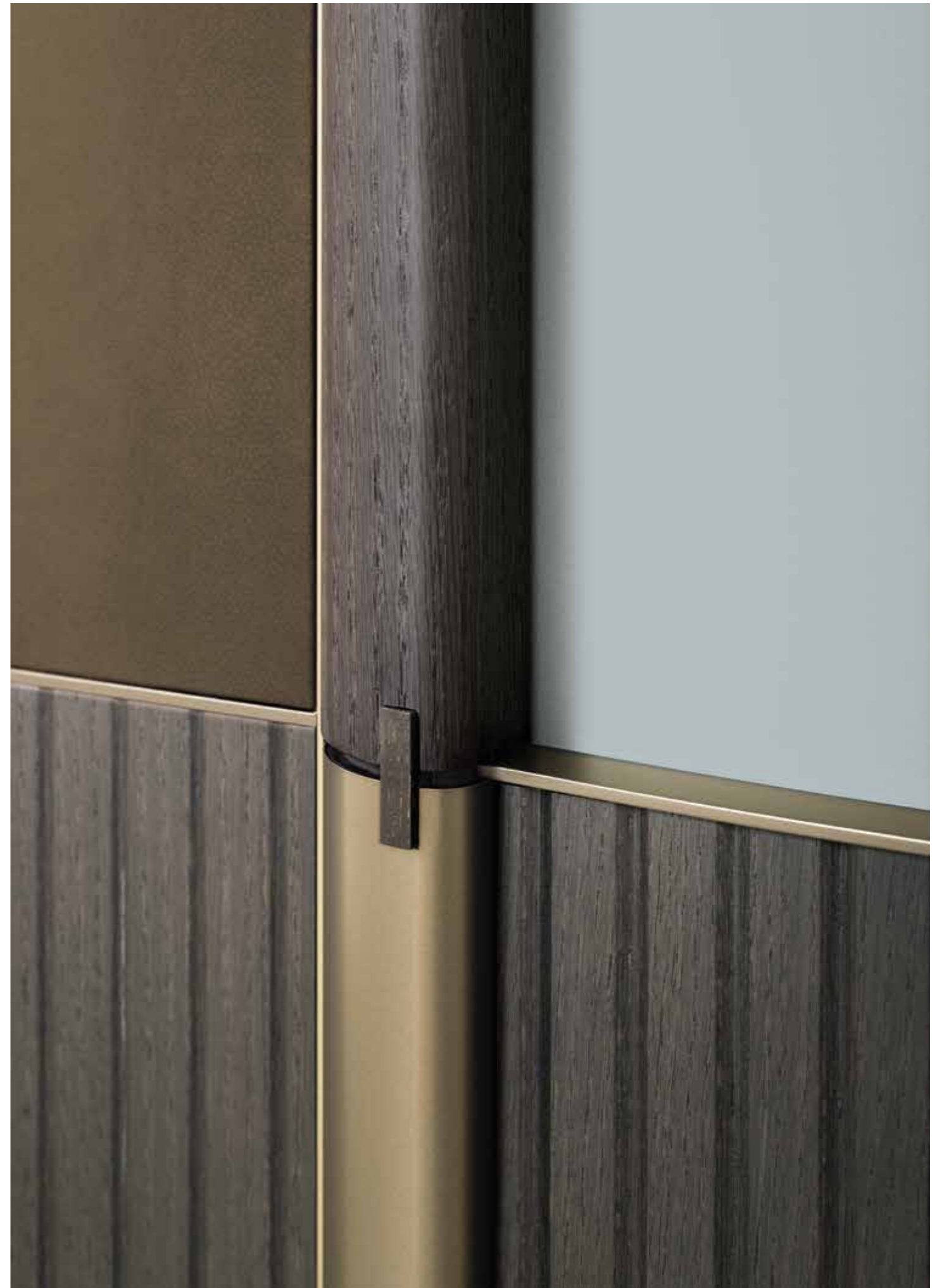





Il disegno di Ying rivela il sofisticato e sottile continuum tra tradizione e modernità, tecniche artigianali e soluzioni industriali, eleganza senza tempo e lusso discreto.

The design of Ying reveals the sophisticated and subtle continuum between tradition and modernity, artisanal techniques and industrial solutions, timeless elegance and restrained luxury.



Armonia cromatica e contemporanea per Ying con l'anta laccata nera opaca, base e stipite in rovere moka e la nota chiara degli inserti in noce canaletto.

Contemporary and coordinated colours for Ying with the matt black lacquered door, the moka oak of the base and jamb and the lighter shades of the canaletto walnut inserts.

Lo stipite lievemente arrotondato in finitura rovere moka si raccorda con naturalezza alla superficie essenziale dell'anta laccata nero opaco.

The slightly rounded jamb in a moka oak finish combines perfectly with the unadorned surface of the matt black lacquered door.

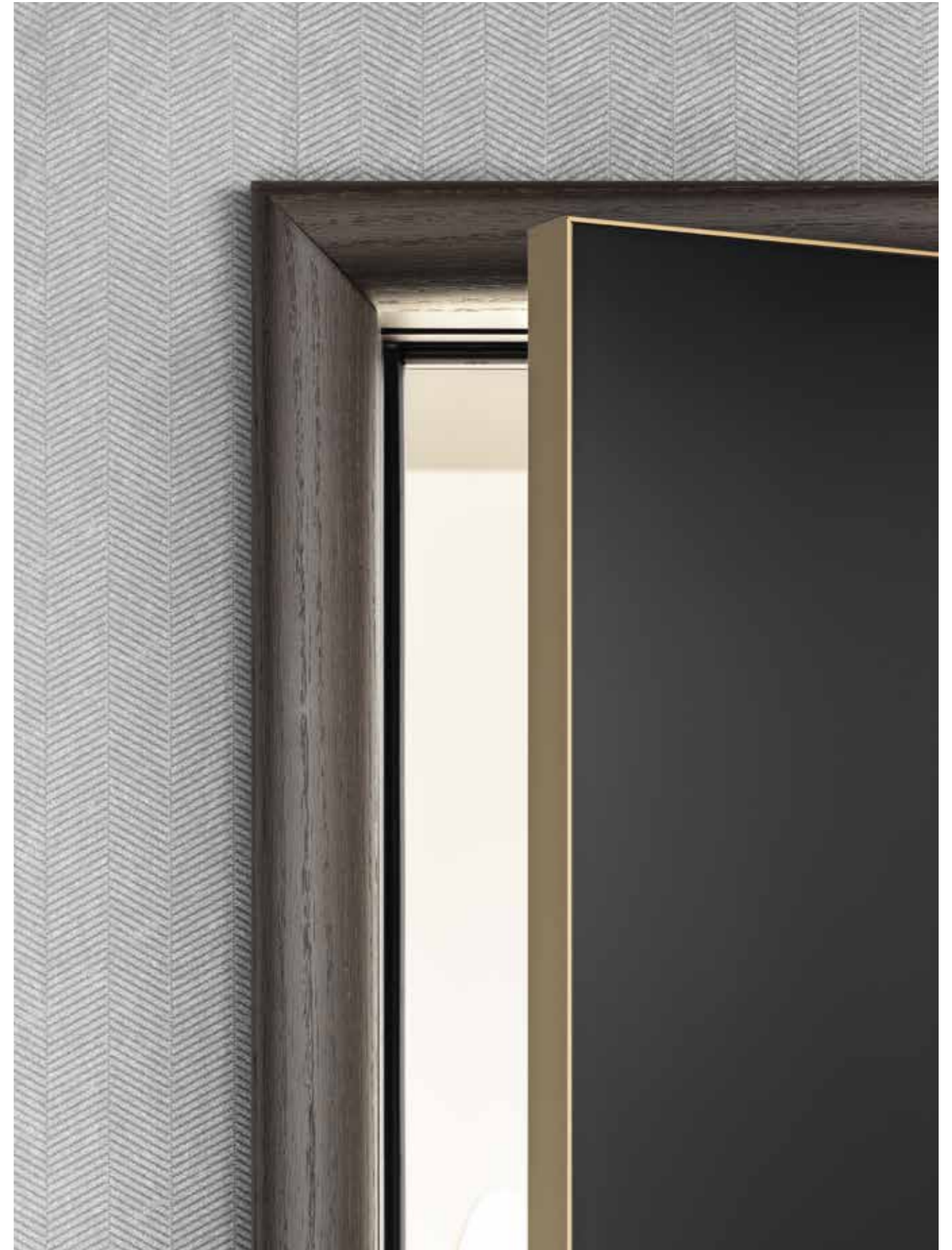

L7

Disegnati da Piero Lissoni nella versione battente, i due modelli L7 sono una presenza lieve e funzionale che sa vivere con garbo in ambienti di gusto contemporaneo. Grazie alla gamma di finiture è possibile definirne la personalità, in relazione all'impatto che si desidera ottenere: dalla naturalità delle sfumature chiare alle superfici retroverniciata in colori lucidi o opachi.

Designed by Piero Lissoni the hinged L7, available in two models, forms a light and functional presence able to inhabit contemporary settings with poise and refinement. Thanks to the range of finishes, the personality can be defined according to the effect desired: from the naturalness of the lighter shades to the gloss or matt back-painted surfaces.

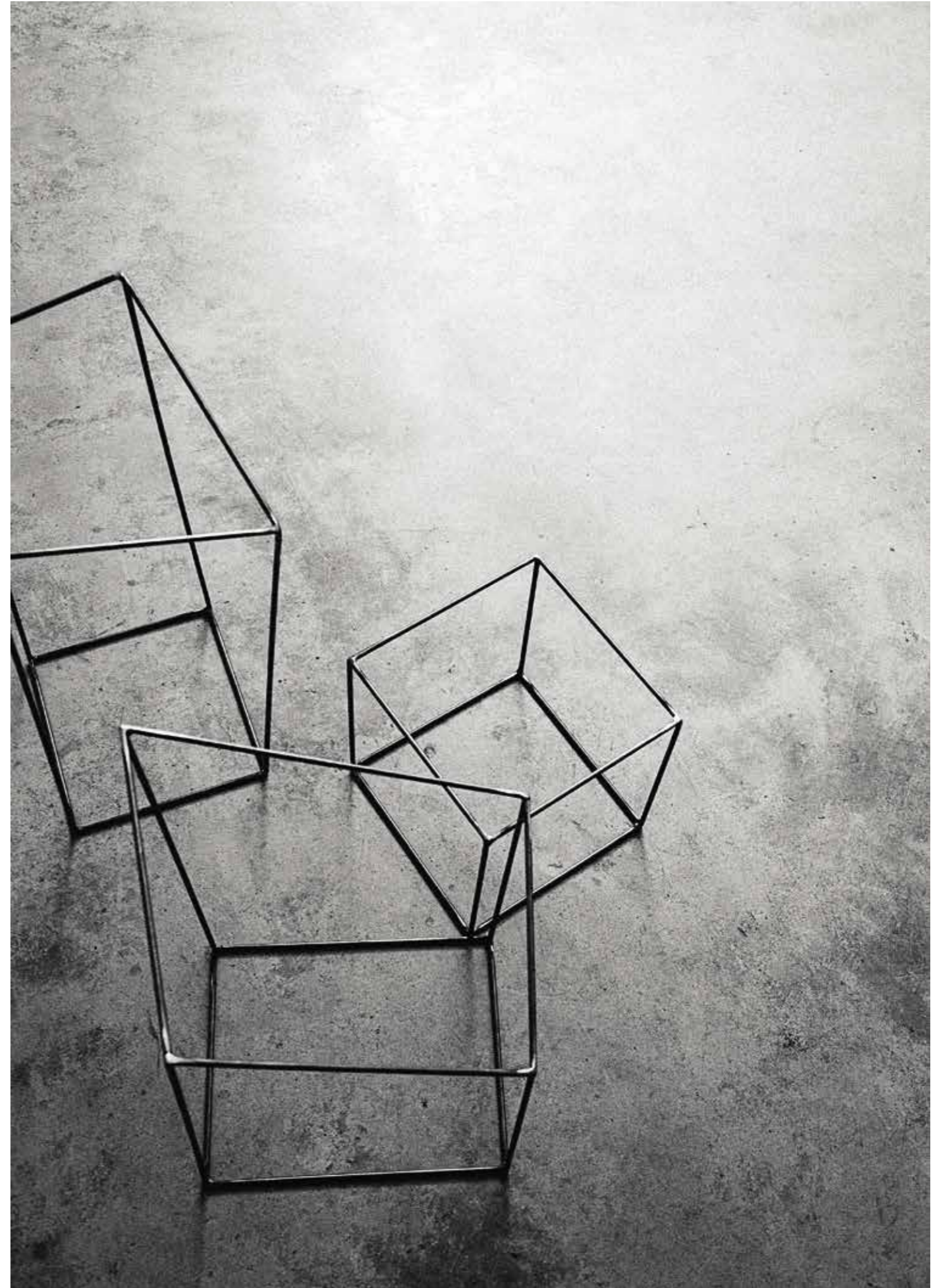



Attraversato dalla luce, il vetro con retina metallica bronzo restituisce ombre dorate. L'anta è a battente, il profilo bronzo.

Traversed by the light, the glass with a bronze metallic lattice renders golden shadows. The door is hinged, the profile bronze.



Il disegno slanciato di L7 versione battente, con profilo in alluminio naturale e vetro retroverniciato bianco, conferisce leggerezza all'ambiente circostante.

With its steel profile and white back-painted glass, the sleek design of L7 in the hinged version confers lightness on the surrounding space.





L7 in versione battente con stipite metallico di 18 mm, profilo in alluminio naturale e vetro retroverniciato bianco.

The hinged version of L7 with 18 mm metal jamb, metal profile and white back-painted glass.





La luminosità di L7 in versione a battente con profilo in bronzo è esaltata dai giochi di rifrazione di Marks extrachiaro satinato.

The luminosity of L7 in the hinged door version with a bronze profile is enhanced by the play of light refractions of the extra-clear satined Marks.





La porta L7 scorrevole a scomparsa con profilo nero e anta in vetro con retina damier, un pattern grafico dal delicato effetto "trompe l'oeil".

The L7 pocket door with black profile and glass door with damier mesh, a pattern with a delicate "trompe l'oeil" effect.





L7 Large

A battente, L7 Large è una porta contemporanea per concezione, uso di materiali e tecnologie, ma classica per estetica. Di linea nitida ed essenziale si presta ad arredare gli ambienti più diversi grazie a una scelta di finiture che giocano con la luce e le trasparenze del vetro e la sofisticata eleganza del metallo.

The L7 Large hinged door is contemporary in its conception, use of materials and technologies, but classic in its aesthetics. With its clean and sober form, it lends itself to furnishing the most diverse settings thanks to a choice of finishes that play with the light and the transparency of glass and the sophisticated elegance of metal.



L7 Large in versione battente con coprifilo incorporato e stipite di 65 mm verniciato bianco. La superficie dell'anta è in vetro satinato.

L7 Large in the hinged version with built in casing and white-painted 65 mm jamb. The surface of the door is in frosted glass.



Grande luminosità per L7 Large con maniglia e stipite bianchi e vetro satinato.

A highly luminous L7 Large with white handle and jamb, in frosted glass.



Una bellezza materica e naturale
per L7 Large con anta in rovere
precomposto e profilo nero
opaco.

A materic and natural beauty
for L7 Large with oak doors
and a matt black profile.





Un volume nitido che ha il calore e la vita del legno, sottolineato dall'eleganza del nero opaco del profilo.

A clear-cut volume that possess the warmth and life of wood, accented by the elegance of the matt black of the profile.

Produce un effetto di morbida luce diffusa questa L7 Large a battente con vetro grigio satinato e profilo nero opaco.

This L7 Large hinged door with grey satined glass and matt black profile produces an effect of soft diffused light.



L41

Progettata da Piero Lissoni, L41 è connotata da un sottile stipite in metallo a valorizzarne il profilo agile. Le finiture diverse creano esiti materici e cromatici, di originale bellezza.

Designed by Piero Lissoni, L41 is distinguished by a thin metal jamb which enhances the light profile. The different finishes provide interesting combinations of materials and colors and a unique beauty.



Una presenza originale capace di valorizzare lo spazio per la linea sofisticata, creata dal contrasto fra l'effetto di profondità dello stipite in alluminio di gusto high tech e la perfetta complanarità di parete e anta.

Forming an original presence, it enhances the space through its sophisticated line created by the contrast between the depth of the aluminium door jamb and the flushness of the wall and door.





Dettaglio dello stipite in alluminio:
una pelle high-tech che corre
lungo tutto il perimetro.

Detail of the doorframe
in aluminium: high-tech leather
edges the entire length of the
perimeter.







Stipite e maniglia in finitura brill spazzolato fanno del metallo il leitmotiv.

Jamb and handle in a satined steel finish make metal the leitmotiv.



Lcd62

Un modello storico, disegnato da Luigi Caccia Dominioni riproposto in un'evoluzione che coinvolge tecnica ed estetica. A renderne più flessibili gli usi sono l'anta reversibile, la cerniera a scomparsa e il telaio telescopico, grazie a cui il modello si adatta a diversi spessori di muratura. Proporzioni e finiture accendono la linea classica di note contemporanee.

An historic model, designed by Luigi Caccia Dominioni, that has evolved both technically and aesthetically. The reversible door, the concealed hinge and the adjustable jamb which adapts to a variety of wall thicknesses, all allow more flexibility in the range of uses. Proportions and finishes lend a contemporary note to this classic line.

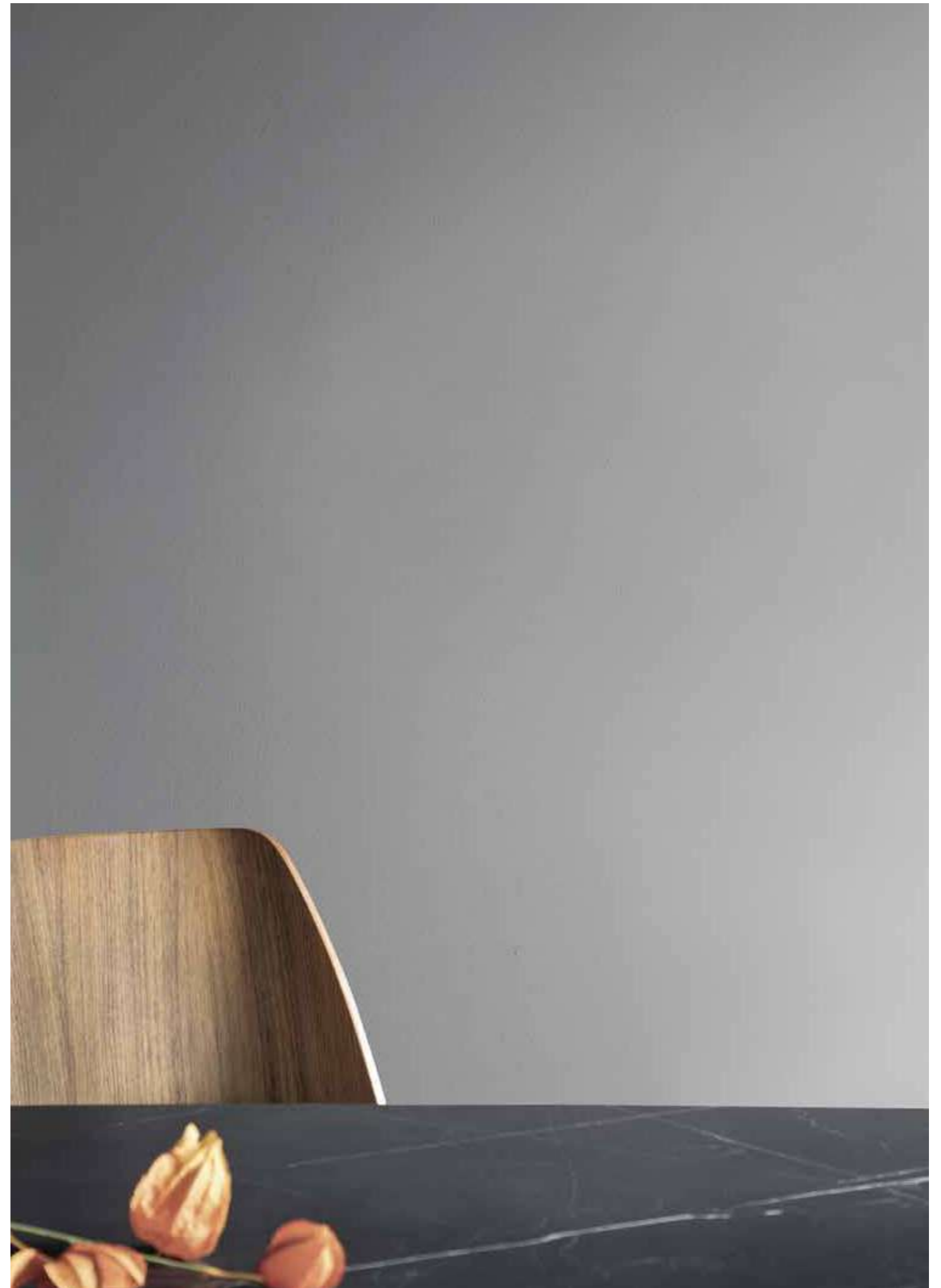





La complanarità dello stipite con l'anta danno eleganza e raffinatezza alla parete.

The flushness of the jamb and door lends elegance and refinement to the wall.



Dettaglio dello stipite esterno,
interno e della battuta con
guarnizione.

Detail of the external and internal
trim and the striker seal.

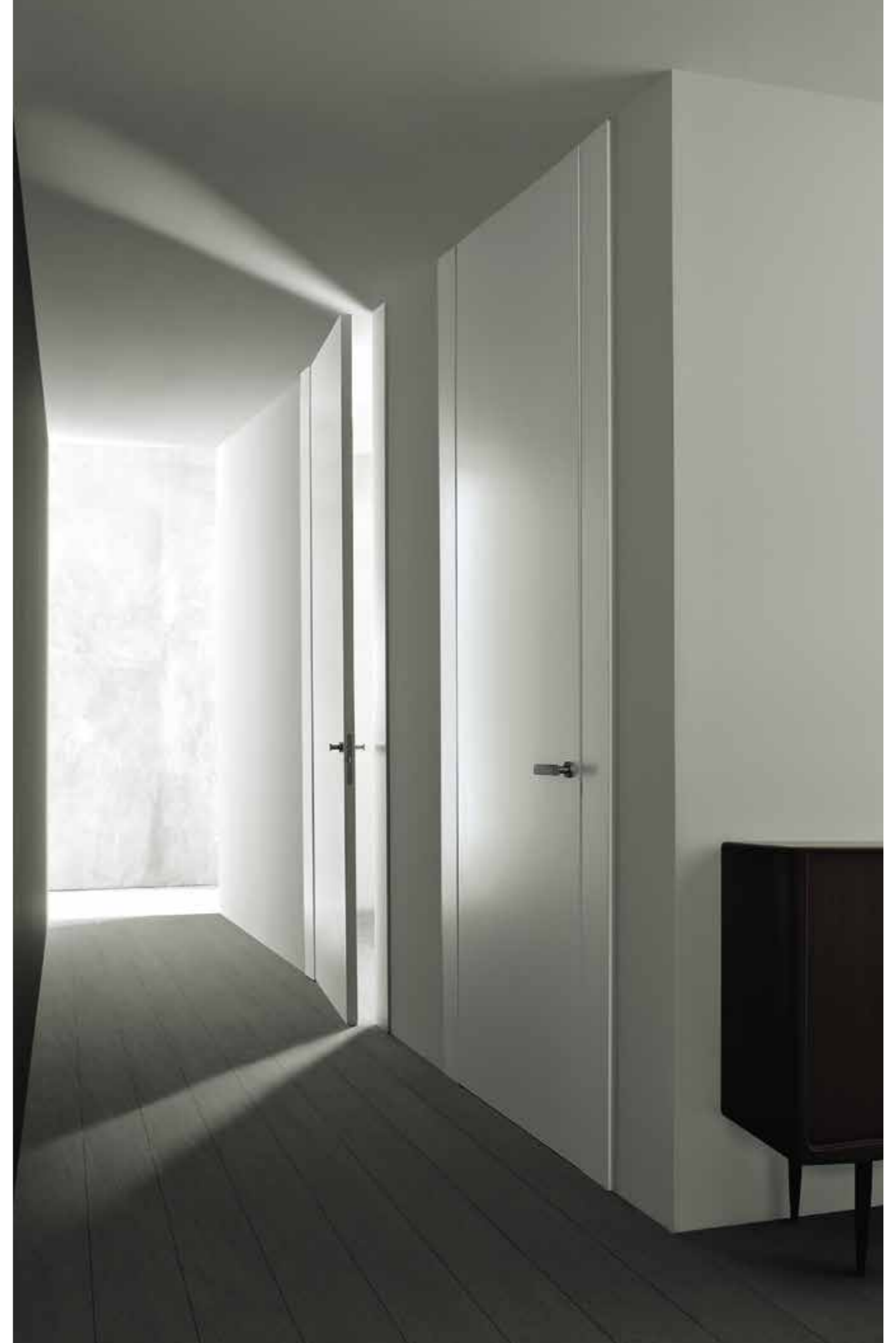

Filo 55 s-t

Perfettamente complanare a stipite e parete, associa alla purezza della superficie una linea slanciata. Grazie alla battuta rovesciata e all'apertura verso l'interno, ottiene un elegante effetto di continuità con i lati del corridoio. Disponibile con apertura a spingere, Filo 55 s, o a tirare Filo 55 t, ha natura versatile e si adatta a muratura, cartongesso e sistemi di pareti mobili.

With the frame and walls perfectly flush, the slim form blends with the purity of the surfaces. The reversed edge and the opening to the interior confer a stylish effect of continuity with the sides of the corridor. Available with push opening, Filo 55 s, or pull opening, Filo 55 t, it is versatile and adapts to solid wall, plasterboard and moveable wall systems.









Con apertura a spingere, Filo 55 s, o a tirare Filo 55 t, sono adatte per essere inserite a muratura, cartongesso e sistemi di pareti mobili.

Filo 55 s with push opening or Filo 55 t with pull opening are suitable for insertion in masonry, plasterboard and mobile wall systems.





Battuta rovesciata e apertura verso l'interno per un elegante effetto di continuità con la superficie delle pareti.

The reversed edge and opening towards the inside confer an elegant continuity with the surface of the walls.

Avenue

Robert A. M. Stern abbina la sofisticatezza italiana a un gusto tipicamente americano, per creare una serie di tre porte nello stile tradizionale-moderno caratteristico del suo lavoro. Le specchiature, dai dettagli vivaci con finitura in legno laccato, reinterpretano le porte degli appartamenti classici della New York anteguerra. Le porte sono disponibili con specchiatura singola, doppia o tripla. Simmetriche ed equilibrate, con i loro dettagli in puro stile americano, sottili e senza tempo, completano una vasta gamma di interni contemporanei e sono adatte sia per l'arredamento residenziale, che per quello da ufficio e per il settore dell'ospitalità.

Robert A. M. Stern combines Italian sophistication with a distinctly American flavor to create a series of three doors in the modern traditional style that is so characteristic of his work. The matt finished paneling details reinterpret the doors of a classic New York pre-war apartment. The doors are available with single, double or triple paneling. Symmetric and balanced, they complement a range of contemporary interiors with subtle, timeless, American details, and are suitable for residential settings as well as hospitality and office applications.





Particolare dello stipite e dell'anta
in laccato opaco colore terra.

Detail of the trim and door
in matt lacquer Earth color.





Porta laccata opaco bianco nella versione con una specchiatura.
Door in a matt white finish with one panel.

Porta laccata opaco bianco nella versione con due specchiature.
Door in a matt white finish with two panels.



Porta laccata opaco bianco nella versione con tre specchiature e decoro.

Door in a matt white finish with three panels and decoration.

Porta laccata bianco opaco nella versione a tre specchiature.

Door in a matt white finish with three panels.



San Siro

Disegnata da Luigi Caccia Dominioni, recupera le forme della tradizione, interpretandone lo spirito classico in chiave moderna. Il gioco di proporzioni e il disegno delle fasce laterali introducono un elemento di lieve dissonanza in una composizione di grande misura, fatta per abitare con facilità ogni tipo di spazio.

Designed by Luigi Caccia Dominioni, this rediscovery of the traditional form interprets the classic spirit in a modern tone. The play of proportions and the design of the side strips introduce a lightly dissonant element into a composition of great dimension, created to fit easily into any type of space.





La rigidità della maniglia
Martina è associata al disegno
classico della porta.

The austerity of the Martina
handle is associated with the
door of classic design.





Drive

Può leggersi come bella superficie semplicemente appoggiata alla parete, questa anta scorrevole la cui tecnologia, completamente a scomparsa, permette di ottenere effetti di grande leggerezza.

This sliding door can be seen as a beautiful surface simply laid against the wall. The technology is totally invisible and creates an effect of extraordinary lightness.







Partitions & Boiserie

[248 - 291]

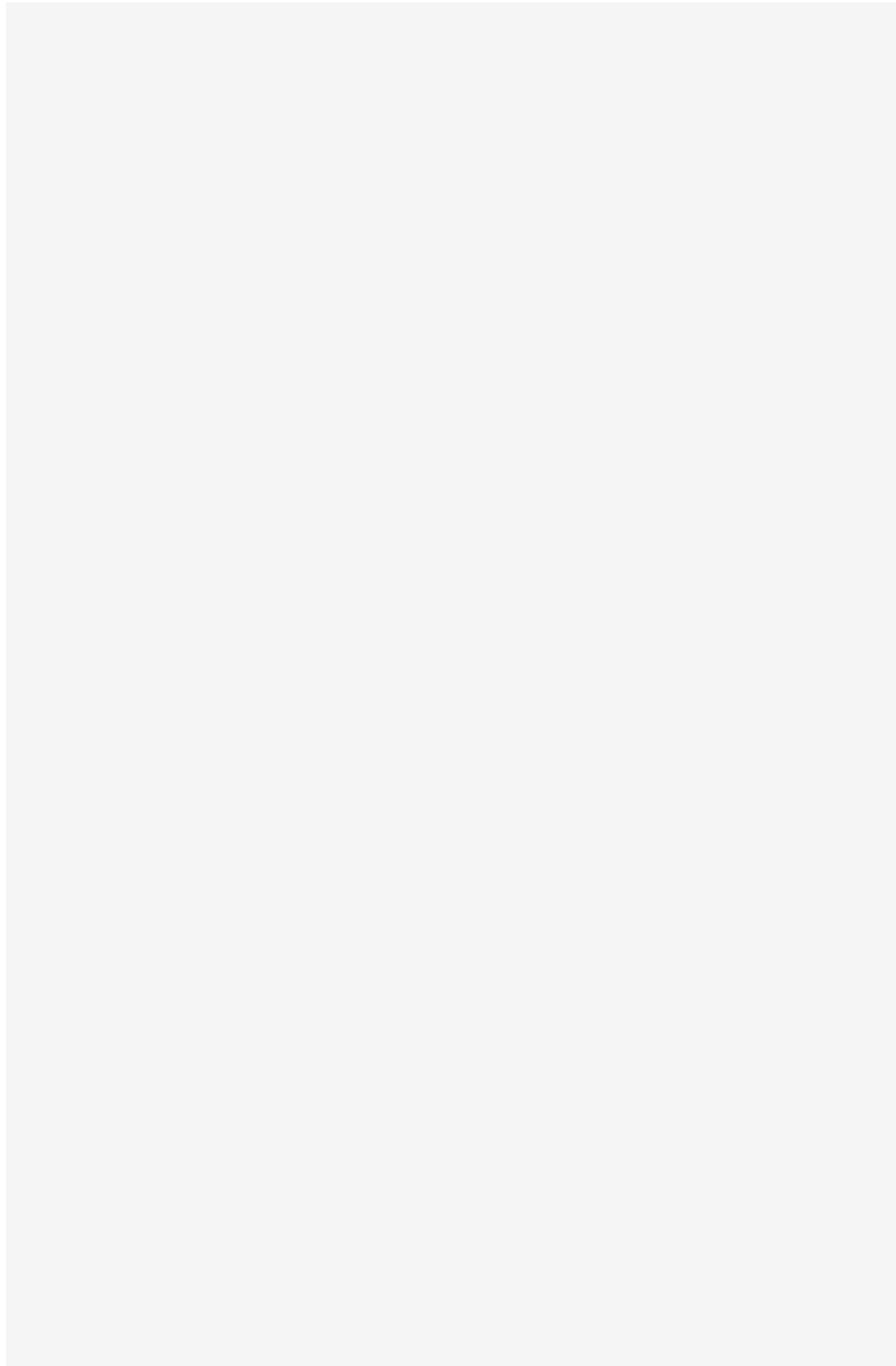

Nobili soluzioni decorative, i sistemi di pannelli modulari di antica tradizione storica, interpretati in termini contemporanei, sono elementi architettonici scenografici capaci con le loro superfici omogenee di dare identità e calore agli ambienti.

Gracious decorative solutions, the modular systems of ancient historical tradition, interpreted in contemporary terms, are spectacular architectural elements capable of conferring identity and adding warmth to settings with their homogeneous surfaces.

Wall&Door

Wall&Door è un sistema che assembla pannelli modulari, ante e porte, pensato come soluzione per razionalizzare, definire e rendere più omogenee le superfici di uno stesso ambiente.

Wall&Door is a system composed of modular panels and doors, created to rationalize, define and harmonize the surfaces of a room.





Composizione parete Wall&Door
in noce canaletto e tappezzeria.
Wall&Door wall composition
in canaletto walnut and upholstery.





La soluzione del bordo in alluminio bronzo è utilizzata quando i due lati della porta sono in finitura diversa.

The solution with a bronze aluminium edging is used when the two sides of the door have a different finish.







La finitura in rovere sbiancato
è una presenza calda e avvolgente.

The white oak finish is a warm
and enveloping presence.

Teatro

Teatro è un sistema divisorio poliedrico, versatile e modulabile. Disegnato dall'architetto Andrea Boschetti, offre infinite possibilità di personalizzazione per creare soluzioni divisorie flessibili e scenografiche. Ogni elemento può essere "vestito" con materiali, colori e pattern diversi.

Teatro is a multifaceted, versatile and modular partition system. Designed by the architect Andrea Boschetti, it offers endless possibilities for customization to create flexible and scenographic partitioning solutions. Each element can be "dressed" with different materials, colors and patterns.









Teatro in versione rovere moka con inserti in bronzo. Ispirato al sipario teatrale, il sistema ha ante pivotanti a chiusura meccanizzata o manuale su uno o più elementi.

Teatro in the mocha oak version with bronze inserts. Inspired by a theatre curtain, the system features pivoting doors with mechanical or manual closing on one or more elements.

Boiserie

Riedizione moderna della tradizione storica, le estese superfici di rivestimento in legno delle boiserie arredano gli interni con eleganza e con uno stile classico, raffinato di gusto contemporaneo, permettendo di realizzare soluzioni progettuali non convenzionali.

A modern re-working of an historical tradition, the large wooden panelled surfaces of the boiserie furnish the interior with elegance and a classic, refined style of contemporary taste, allowing the creation of unconventional design solutions.





La porta è perfettamente
integrata nella boiserie.
Finitura thermowood.

The door is perfectly
integrated into the boiserie.
Thermowood finish.

Doors | Systems

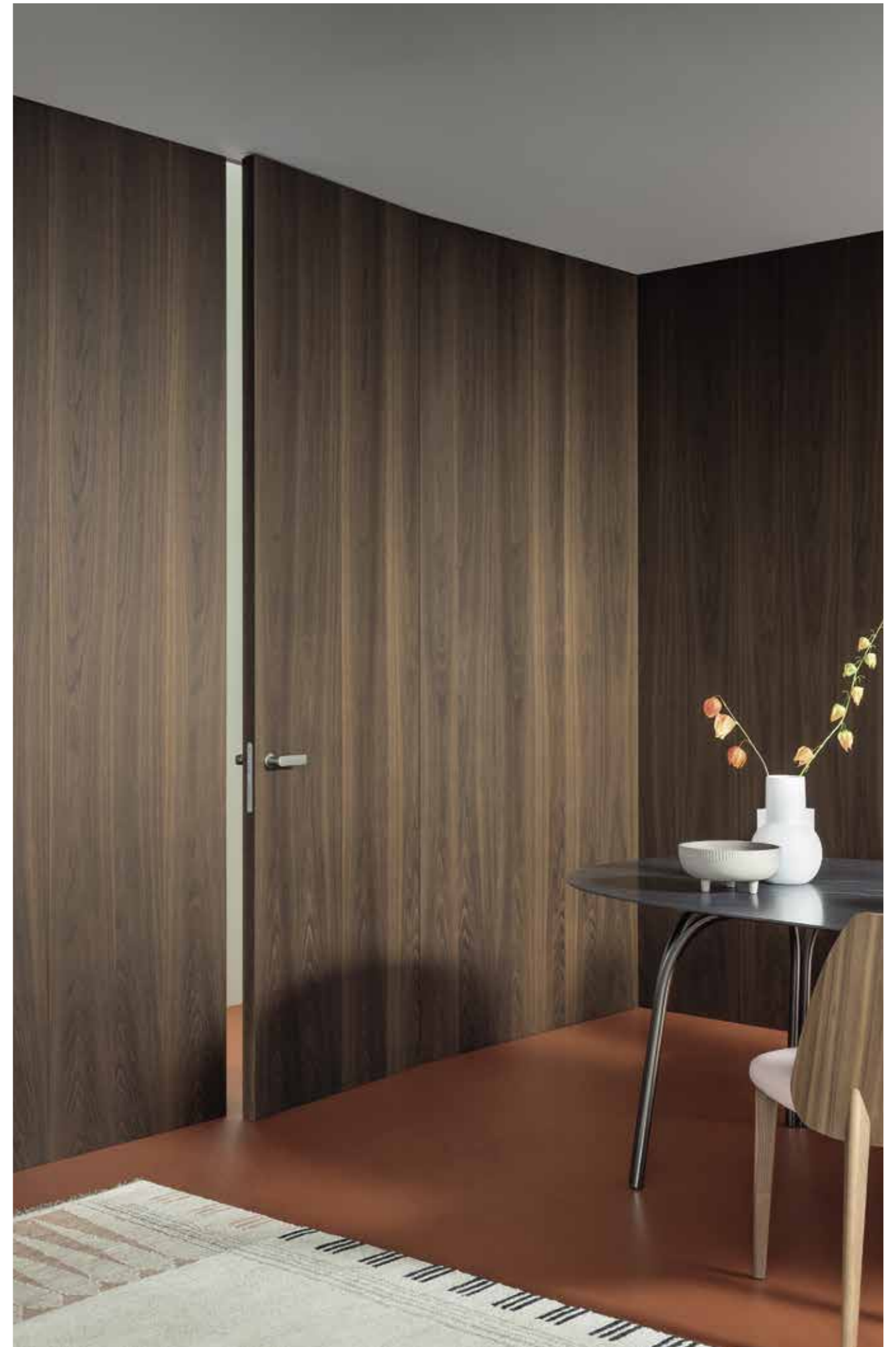

Avenue Boiserie

Avenue, di Robert A. M. Stern, offre una riedizione del gusto anglosassone per l'eleganza più classica, studiata su moduli dalle dimensioni non convenzionali.

Avenue, by Robert A. M. Stern, presents a new reading of the Anglo-Saxon taste for a more classical elegance, studied around forms of unconventional dimensions.









Edge Boiserie

Ispirata alla tradizione della boiserie, Edge di Marco Piva interpreta la porta come elemento flessibile e innovativo, capace di espandersi alle superfici circostanti in funzione decorativa e di rivestimento, ma non solo. Sofisticata estensione architettonica, Edge, grazie ai caratteristici tagli del pannello che danno volume a una superficie di solito bidimensionale, è in grado di connotare lo spazio. Il delicato disegno a rilievi e geometrie gioca con luci e ombre, conferendo grazia inedita al passaggio fra ambienti.

Inspired by the tradition of the boiserie, Edge by Marco Piva interprets the door as a flexible and innovative element, able to expand into the surrounding surfaces as decorative cladding. A sophisticated architectural extension, Edge is able to characterize the space thanks to the distinctive cuts of the Panel that lend volume to a normally two-dimensional surface. The delicate and geometric relief pattern plays with light and shadow, bestowing unprecedented grace on the passage between rooms.

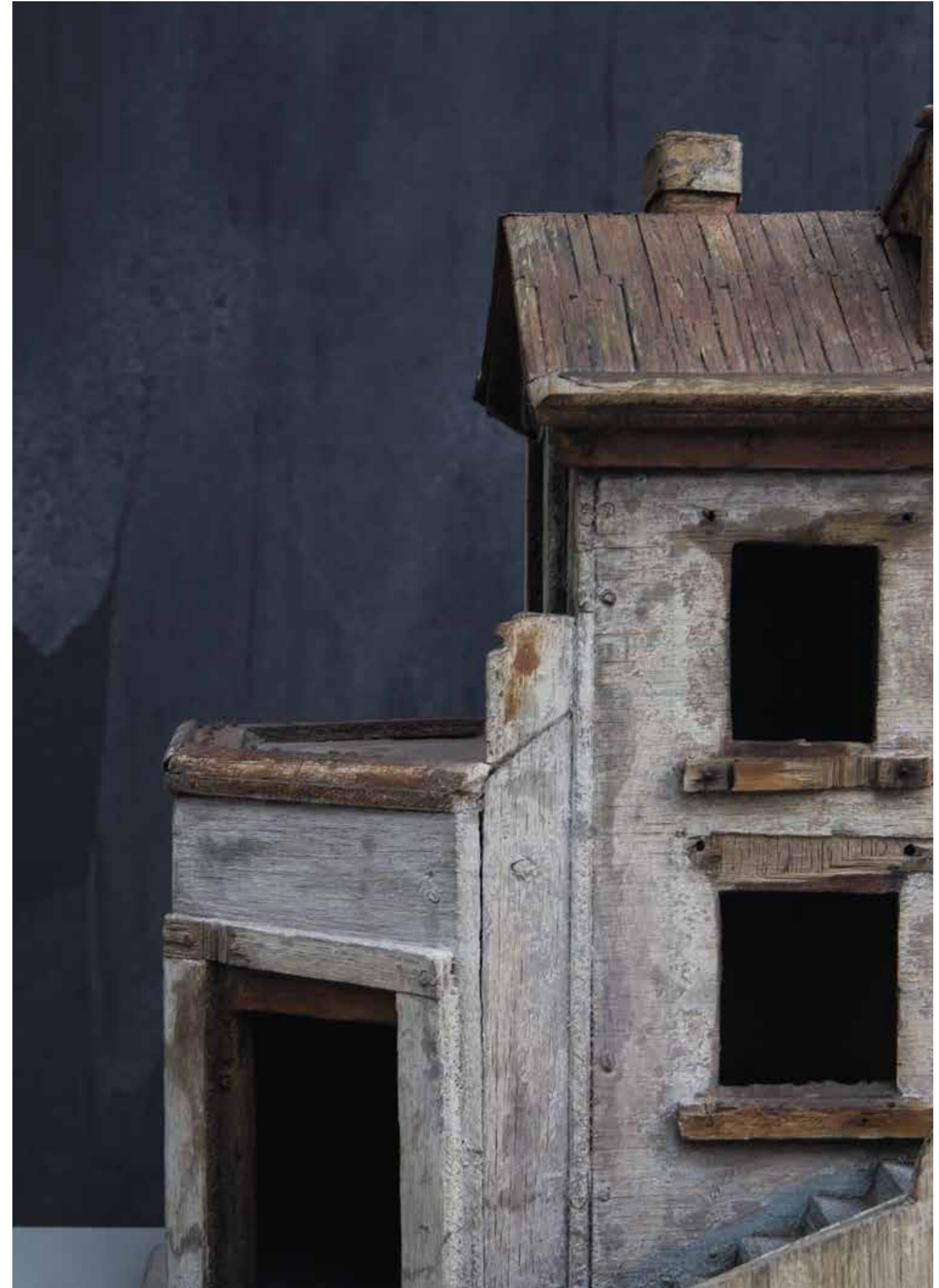



Il delicato disegno geometrico a rilievo tridimensionale di Edge gioca con luci e ombre, conferendo dinamicità alla parete.

The delicate and geometric three-dimensional relief pattern of Edge plays with light and shadow, lending vibrancy to the wall.

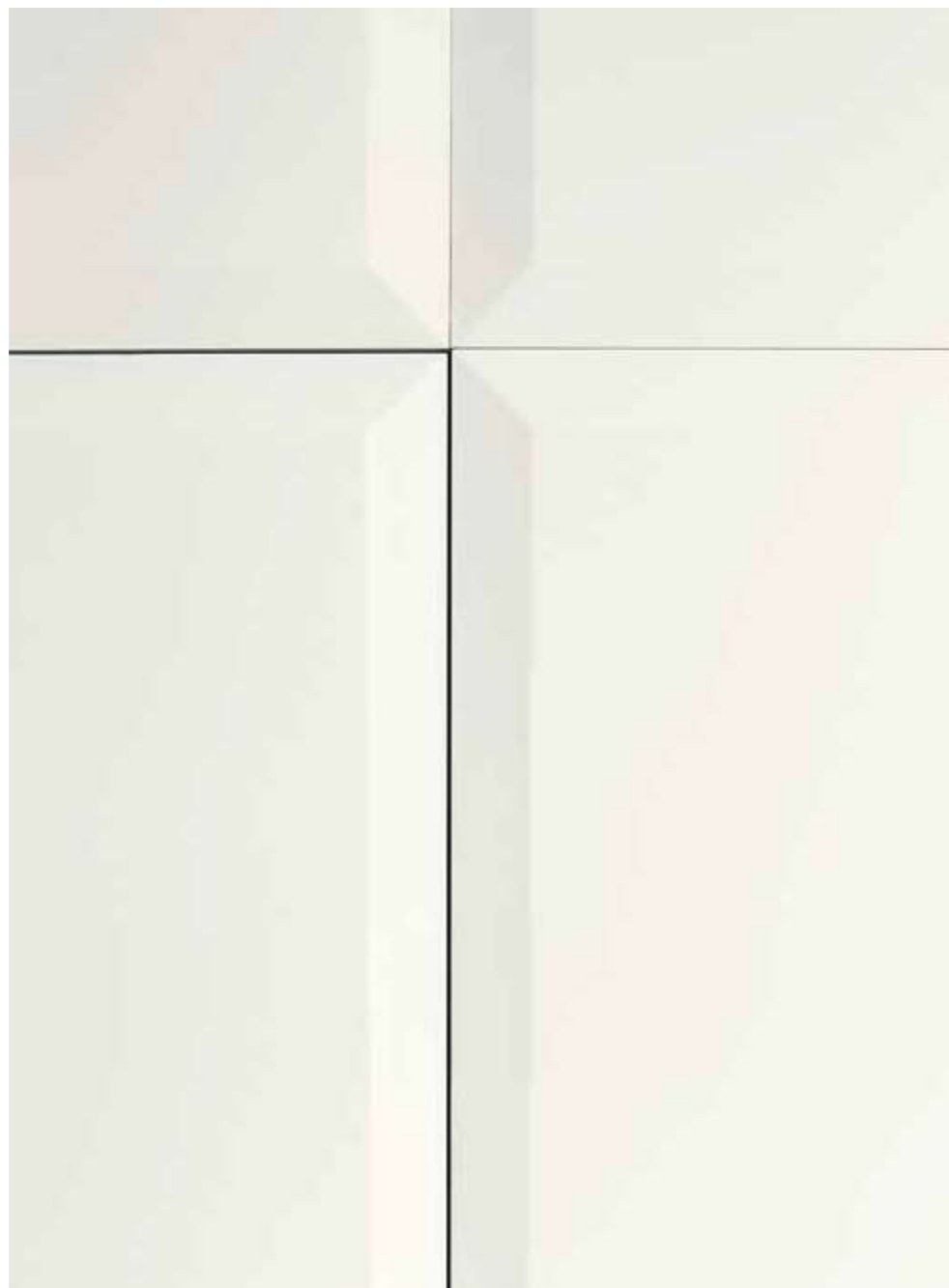

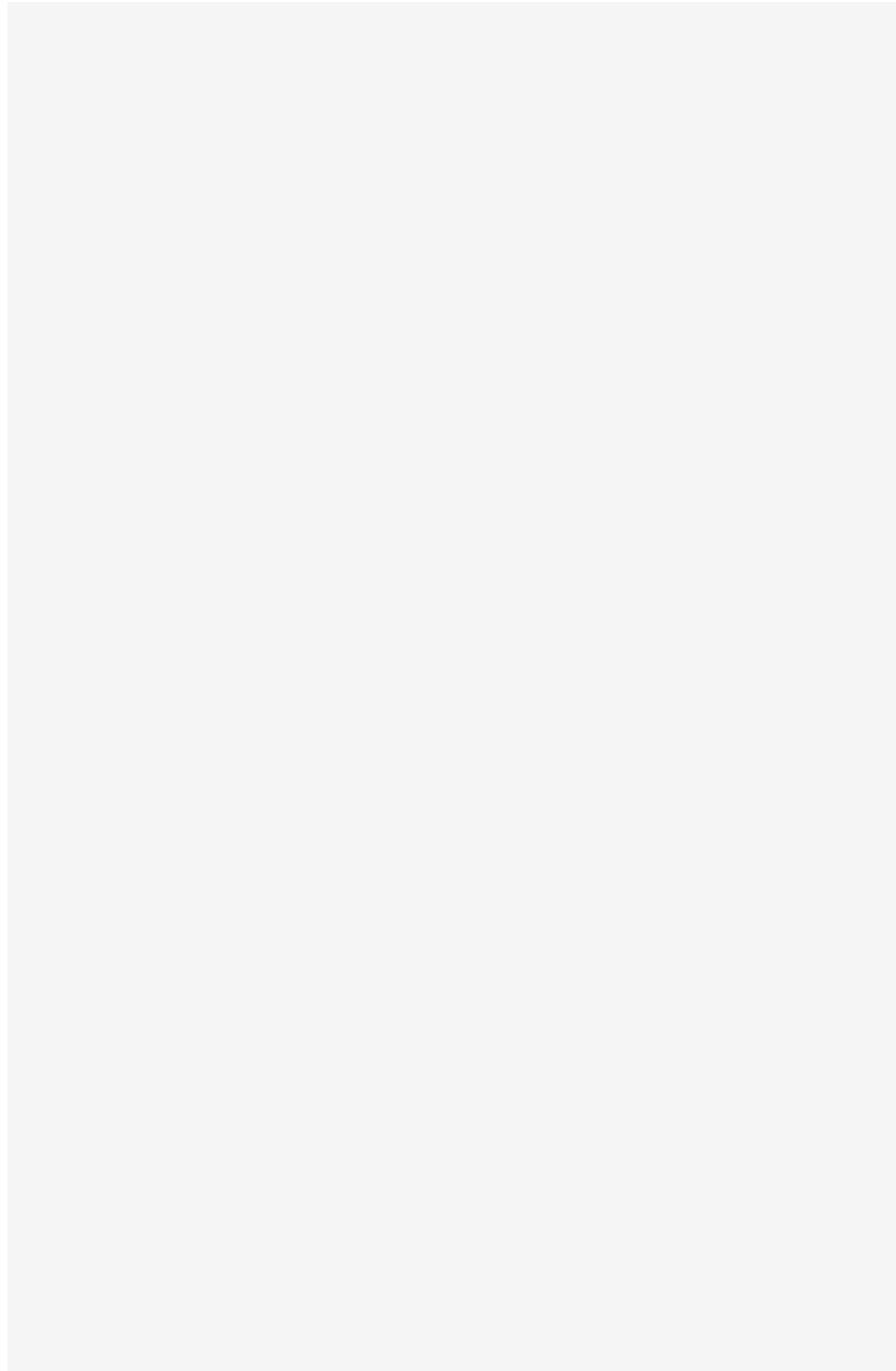

*Technical drawings,
Handles, Finishes*

**L7 / L7 Plus
sistema scorrevole**

L7 / L7 Plus scorrevole, sistema di ante fisse e scorrevoli con spessore 41 mm realizzate su misura. Ante in vetro di sicurezza 6 mm. Telaio di contenimento del vetro in alluminio trattato in diverse finiture. Binario a una o due vie, sistema di freno decelerante. Meccanismo di regolazione in altezza nascosto nel carrello del binario.

L7 / L7 Plus sliding door, system with fixed and sliding panels mm 41 thick, custom made. Leaf with safety glass mm 6 thick and aluminium frame in different finishes. Single or double rail with damper system and trolley hanger with height adjustment mechanism.

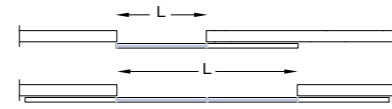

Binario singolo / Single track

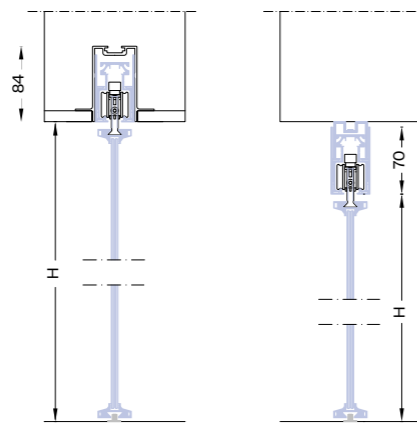

L
luce netta / opening width
600-1400 mm 23 5/8" - 55 1/2"
H
altezza netta / opening height
max 3000 mm 118 1/4"

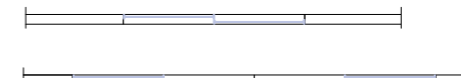

Binario doppio / Double track

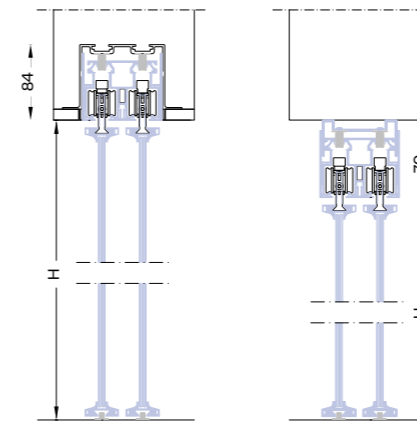

Shoin / Koan / Koan Plus sistema scorrevole

Anta di spessore 50 mm, configurabile in diversi sistemi di pannelli scorrevoli e fissi, disponibile con vetro di sicurezza spessore 6 mm e profilo in alluminio. Binario con sistema decelerante e carrello con meccanismo di regolazione in altezza.

Door leaf 50 mm (2") thick, available with fixed and sliding panels and with 6 mm (1/4") thick safety glass and aluminium trim. Track with damper system and trolley hanger with height adjustment mechanism.

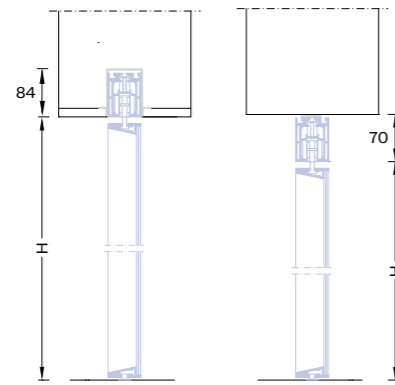

Binario singolo / Single track

L
luce netta / opening width
600-1400 mm 23 5/8" - 55 1/2"
H
altezza netta / opening height
max 3000 mm 118 1/4"

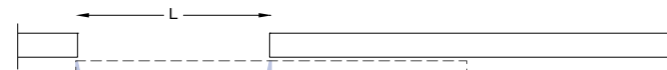

Anta singola esterno muro / External single door leaf



Due ante esterno muro / External double door leaves

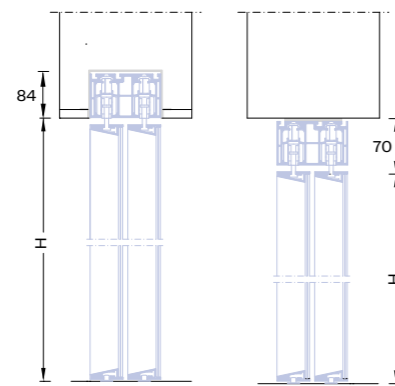

Binario doppio / Double track

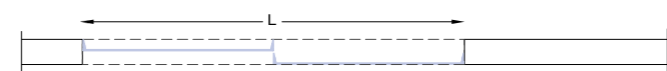

Due ante interno muro / Internal double door leaves

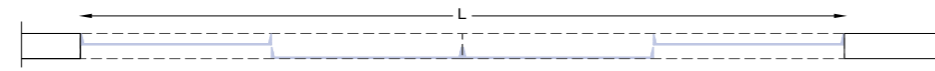

Quattro ante interno muro / Internal four door leaves

Shoin Pivot

Porta a bilico di spessore 50 mm, configurabile in diversi sistemi di pannelli apribili e fissi, disponibile con vetro di sicurezza spessore 6 mm e profilo in alluminio. Completa di serratura e perni di fissaggio. Binario a soffitto.

Pivoting door 50 mm (2") thick that can be configured in different systems with fixed and pivoting panels, available in 6 mm (1/4") thick safety glass and profile in aluminium. Complete with lockset and pivot hinges. Track available for fixed panels. Recessed or ceiling surface mounted.

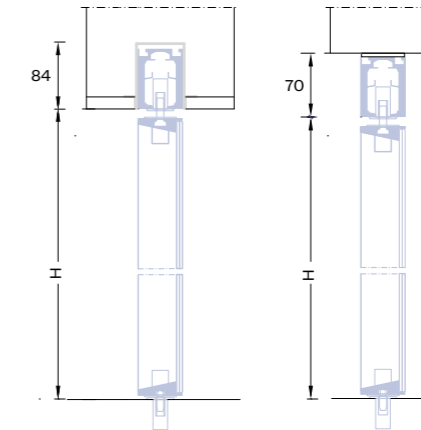

L
larghezza pannello apribile /
width opening panel
cm 80 - 120 31 1/2" - 47 1/4"
LP
larghezza pannello fisso /
width fixed panel
cm 60 - 120 23 5/8" - 47 1/4"
H
altezza luce netta / opening height
cm max 300 118 1/4"

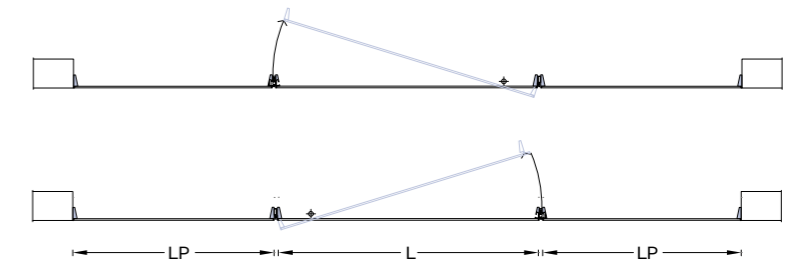

Sliding 50

Anta di spessore 50 mm configurabile in diversi sistemi di pannelli scorrevoli e fissi, disponibili in essenza o laccato. Binario con sistema decelerante e carrello con meccanismo di regolazione in altezza.

The mm 50 thick door can be configured in different sliding and fixed panel systems, and is available veneered or lacquered. Track with a damper system and carriage with height adjustment mechanism.

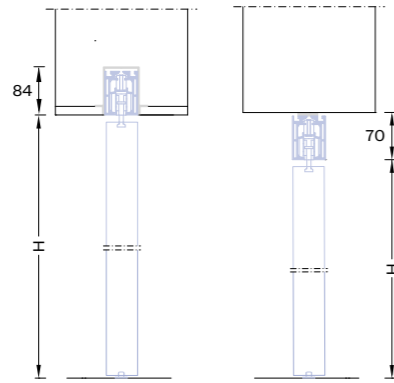

Binario singolo / Single track

L
luce netta / opening width
600-1400 mm 23 5/8" - 55 1/2"
H
altezza netta / opening height
max 3000 mm 118 1/4"

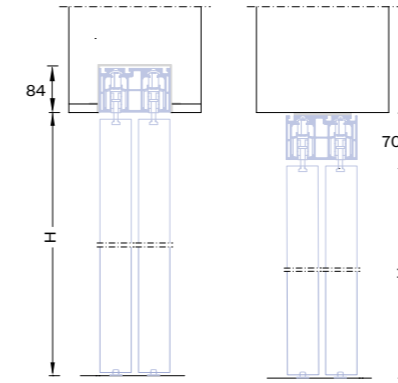

Binario doppio / Double track

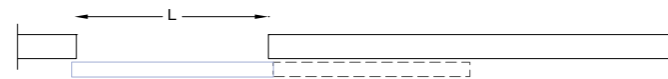

Anta singola esterno muro / External single door leaf



Due ante esterno muro / External double door leaves

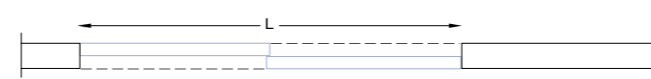

Due ante interno muro / Internal double door leaves

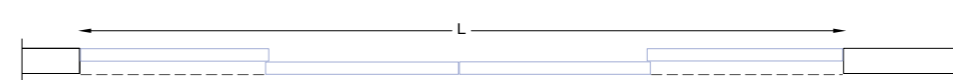

Quattro ante interno muro / Internal four door leaves

Rasomuro 55s

Anta a battente in tamburato, spessore 55 mm.
 Finiture del battente: grezzo con una mano di fondo; laccato opaco e laccato lucido nei colori di serie o essenze. Telaio in alluminio; non necessita di falso telaio. Guarnizione di battuta. Cerniera a scomparsa regolabile.

Hollow-core hinged door, mm 55 thick.
 Door panel: unfinished with a primer coat, gloss or matt lacquered from the standard color range, or veneered. Aluminium frame for direct wall installation. Subframe not necessary. Door striker seal. Adjustable concealed hinges.

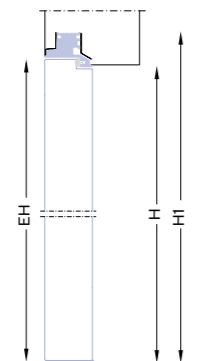
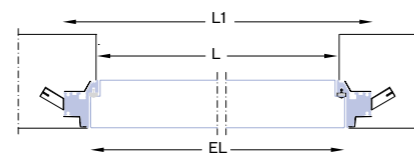
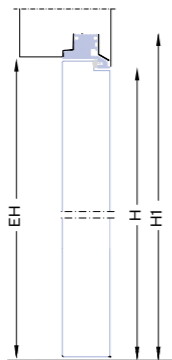
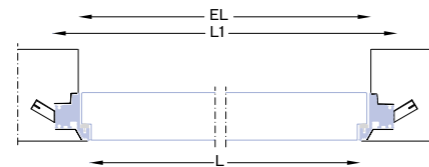

RM55s spingere per muratura / Brickwall push opening

L
 luce netta / opening width
 600-900 mm 23 5/8"- 35 3/8"
H
 altezza netta / opening height
 max 3000 mm 118 1/4"
L1
 vano muro / rough opening
 L + 100 mm
H1
 vano muro / rough opening
 H + 50 mm
EL
 ingombro totale / overall sizes
 L + 32 mm
EH
 ingombro totale / overall sizes
 H + 16 mm

RM55s tirare per muratura / Brickwall pull opening

L
 luce netta / opening width
 600-900 mm 23 5/8"- 35 3/8"
H
 altezza netta / opening height
 max 3000 mm 118 1/4"
L1
 vano muro / rough opening
 L + 100 mm
H1
 vano muro / rough opening
 H + 50 mm
EL
 ingombro totale / overall sizes
 L + 32 mm
EH
 ingombro totale / overall sizes
 H + 16 mm

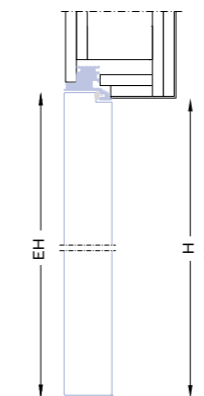
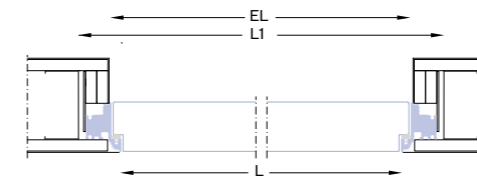

RM55s spingere per cartongesso / Drywall push opening

L
 luce netta / opening width
 600-900 mm 23 5/8"- 35 3/8"
H
 altezza netta / opening height
 max 3000 mm 118 1/4"
L1
 vano muro / rough opening
 L + 100 mm
H1
 vano muro / rough opening
 H + 50 mm
EL
 ingombro totale / overall sizes
 L + 32 mm
EH
 ingombro totale / overall sizes
 H + 16 mm

RM55s tirare per cartongesso / Drywall pull opening

L
 luce netta / opening width
 600-900 mm 23 5/8"- 35 3/8"
H
 altezza netta / opening height
 max 3000 mm 118 1/4"
L1
 vano muro / rough opening
 L + 100 mm
H1
 vano muro / rough opening
 H + 50 mm
EL
 ingombro totale / overall sizes
 L + 32 mm
EH
 ingombro totale / overall sizes
 H + 16 mm

Rasoline 55s

Anta di spessore 55 mm in legno a struttura tamburata e bordo in alluminio. Completa di serratura magnetica, cerniere a scomparsa regolabili sui tre assi e guarnizioni di battuta.

Telaio in alluminio anodizzato preassemblato da murare senza falso telaio. L'anta può essere ridotta di spessore fino a 4 mm su entrambi i lati per accogliere rivestimenti di diversi materiali.

Hinged hollow-core wood door, with edges in aluminium, mm 55 (2 3/16") thick. Complete with magnetic lockset, concealed 3-way adjustable hinges and striker seal.

Anodized aluminium frame to be installed without need of any subframe. The door can be reduced in thickness up to mm 4 (1/8") on each side to accommodate claddings of different materials.

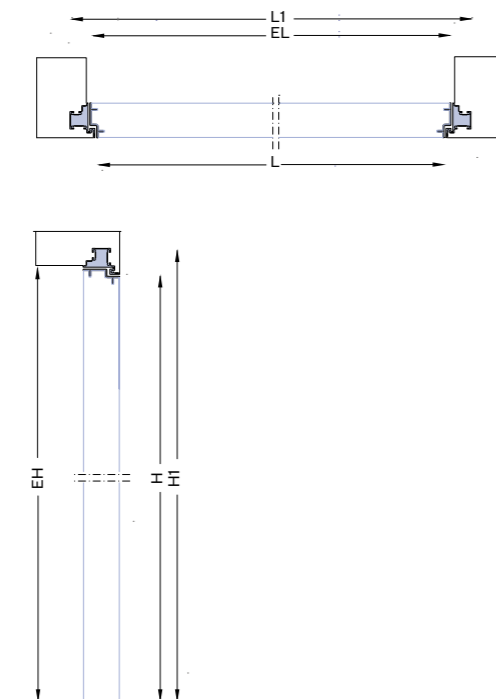

L
luce netta / opening width
600-900 mm 23 5/8" - 35 3/8"

H
altezza netta / opening height
max 3000 mm 118 1/4"

L1
vano muro / rough opening
L + 100 mm

H1
vano muro / rough opening
H + 50 mm

EL
ingombro totale / overall sizes
L + 32 mm

EH
ingombro totale / overall sizes
H + 16 mm



Versione bordo alluminio / Aluminium edge version



Ribasso (da 1 a 4 mm) - lato a tirare / Pull side lowered (from 1 to 4 mm)

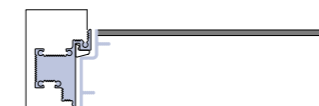

Ribasso (da 1 a 4 mm) - lato a spingere / Push side lowered (from 1 to 4 mm)



Ribasso (da 1 a 4 mm) - entrambi i lati / Both side lowered (from 1 to 4 mm)

Rasotouch 55s

Battente spessore 55 mm con maniglia a scomparsa, l'apertura è ottenuta con pressione della fascia verticale. Battente laccato opaco, lucido o in essenza di serie. Fascia a pressione sempre laccata colore opaco. Telaio in alluminio.

Hinged wood door, mm 55 thick, with a concealed handle operated by pushing the vertical strip. Finished in matt or gloss lacquer or wood veneer from the standard range, while the vertical strip of the handle is always matt lacquered. Aluminum frame.

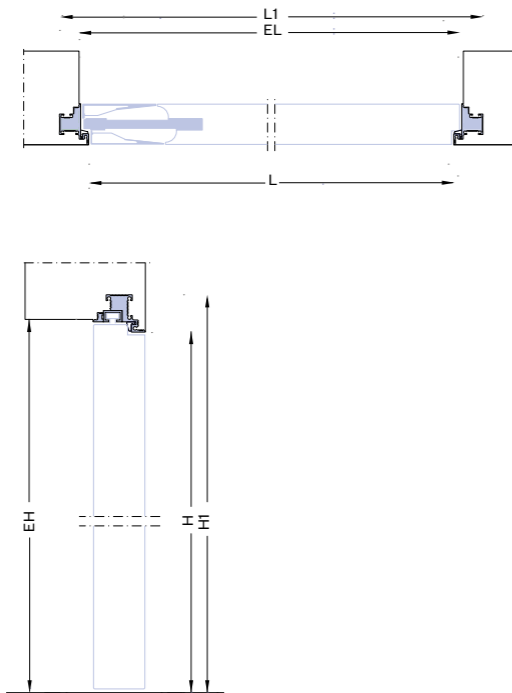

L
luce netta / opening width
600-900 mm 23 5/8" - 35 3/8"

H
altezza netta / opening height
max 3000 mm 118 1/4"

L1
vano muro / rough opening
L + 100 mm

H1
vano muro / rough opening
H + 50 mm

EL
ingombro totale / overall sizes
L + 32 mm

EH
ingombro totale / overall sizes
H + 16 mm

Rasovetro 55s

Battente spessore 55 mm con telaio perimetrale in alluminio e lastre di vetro temperato spessore 4 mm da entrambi i lati. Vetri finiture di serie. Telaio in alluminio.

Hinged door, mm 55 thick, with aluminum frame and mm 4 tempered glass thick on both sides. Finishes from the standard range.

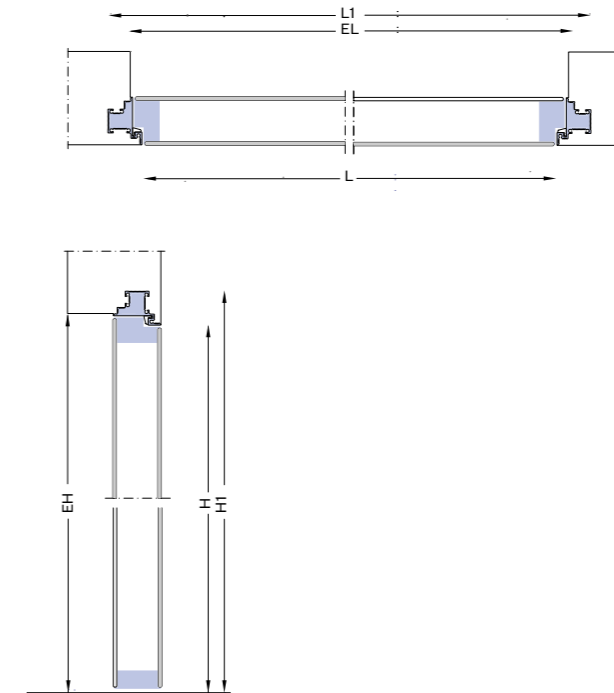

L
luce netta / opening width
600-900 mm 23 5/8" - 35 3/8"

H
altezza netta / opening height
max 3000 mm 118 1/4"

L1
vano muro / rough opening
L + 100 mm

H1
vano muro / rough opening
H + 50 mm

EL
ingombro totale / overall sizes
L + 32 mm

EH
ingombro totale / overall sizes
H + 16 mm

Edge

La porta Edge può essere montata sui telai Rasomuro 55s.
Battente tamburato, spessore 63 mm
finitura del battente laccato opaco colori di serie.
Rilievo lato a spingere o tirare.

The Edge door can be mounted on Rasomuro 55s frames.
Hollow-core hinged door, thickness mm 63, matt lacquered finish from the standard color range.
Shaped on push or on pull side.

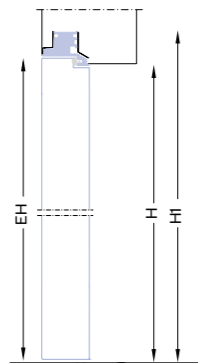
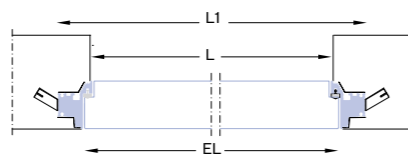
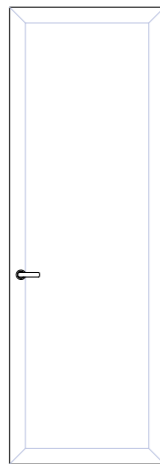

L
luce netta / opening width
700-900 mm 27 1/2"- 35 3/8"
H
altezza netta / opening height
max 3000 mm 118 1/4"
L1
vano muro / rough opening
L + 100 mm
H1
vano muro / rough opening
H + 50 mm
EL
ingombro totale / overall sizes
L + 32 mm
EH
ingombro totale / overall sizes
H + 16 mm

RM55s tirare per muratura / Brickwall pull opening

L
luce netta / opening width
600-900 mm 23 5/8"- 35 3/8"
H
altezza netta / opening height
max 3000 mm 118 1/4"
L1
vano muro / rough opening
L + 100 mm
H1
vano muro / rough opening
H + 50 mm
EL
ingombro totale / overall sizes
L + 32 mm
EH
ingombro totale / overall sizes
H + 16 mm

Raso USA

Anta a battente in tamburato spessore mm 55. Finitura del battente grezzo con una mano di fondo; laccato opaco e laccato lucido nei colori di serie o essenze. Stipite in alluminio a vista, spessore 13 mm, nelle diverse finiture di serie. Non necessita di falso telaio. Guarnizioni di battuta. Cerniere a scomparsa regolabile.

Hinged door in mm 55 thick hollow-core. Door panel finished with a base coat, matt or gloss lacquered in the standard colors or veneered. Visible, mm 13 thick aluminium jamb in a variety of standard finishes. No frame needed. Striker seals. Adjustable concealed hinges.

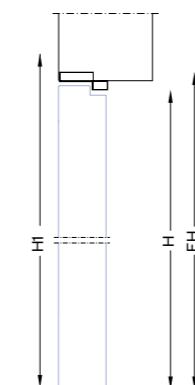
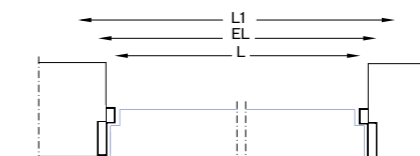
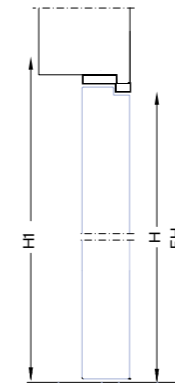
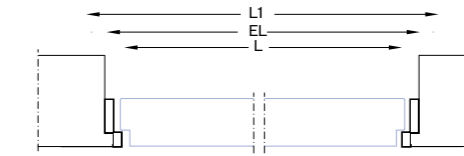

Raso USA spingere / Push opening

L
luce netta / opening width
700-900 mm 27 1/2"- 35 3/8"
H
altezza netta / opening height
max 3000 mm 118 1/4"
L1
vano muro / rough opening
L + 126 mm
H1
vano muro / rough opening
H + 63 mm
EL
ingombro totale / overall sizes
L + 48 mm
EH
ingombro totale / overall sizes
H + 24 mm

Raso USA tirare / Pull opening

L
luce netta / opening width
700-900 mm 27 1/2"- 35 3/8"
H
altezza netta / opening height
max 3000 mm 118 1/4"
L1
vano muro / rough opening
L + 126 mm
H1
vano muro / rough opening
H + 63 mm
EL
ingombro totale / overall sizes
L + 48 mm
EH
ingombro totale / overall sizes
H + 24 mm

Compass 55

Porta a bilico con anta a struttura tamburata di spessore 55 mm.
 Finitura del battente: grezzo con mano di fondo, laccato lucido o opaco nei colori di serie, impiallacciato verticalmente in essenze di serie.
 Impiallacciatura orizzontale solo su richiesta. Telaio-stipite in alluminio anodizzato preassemblato da murare. Non necessita di falso telaio.
 Guarnizioni di battuta.

Pivoting door, mm 55 thick with hollow-core structure.
 Door panel: unfinished with a primer coat, gloss or matt lacquered from the standard color range, vertical veneers from the standard range.
 Horizontal veneer on request.
 Jamb and frame in pre-assembled anodized aluminium for direct wall installation. Subframe not necessary.
 Door striker seal.

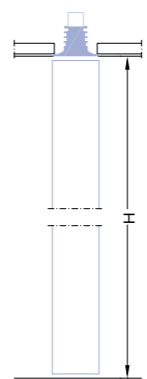
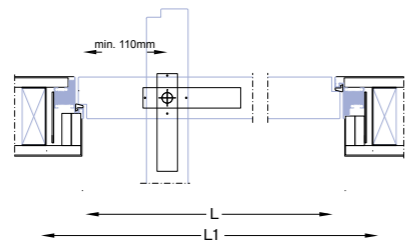
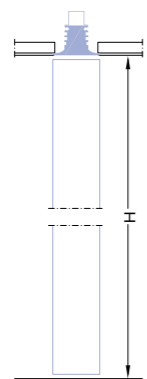
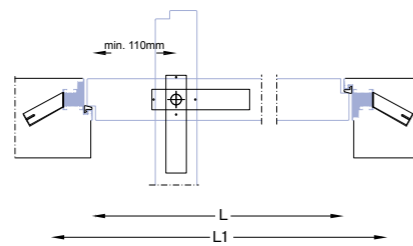

Versione per muratura / Brickwall

L
 luce netta / opening width
 700-900 mm 27 1/2" - 35 3/8"

H
 altezza netta / opening height
 max 3000 mm 118 1/4"

L1
 vano muro / rough opening
 L + 100 mm

H1
 vano muro / rough opening
 H + 53 mm

Versione per cartongesso / Drywall

L
 luce netta / opening width
 700-900 mm 27 1/2" - 35 3/8"

H
 altezza netta / opening height
 max 3000 mm 118 1/4"

L1
 vano muro / rough opening
 L + 100 mm

H1
 vano muro / rough opening
 H + 53 mm

Compass 55 senza battuta

Porta a bilico con anta a struttura tamburata di spessore 55 mm.
 Finitura del battente: grezzo con mano di fondo, laccato lucido o opaco nei colori di serie, impiallacciato verticalmente in essenze di serie.
 Impiallacciatura orizzontale solo su richiesta. Traverso in alluminio anodizzato preassemblato da murare. Non necessita di falso telaio.
 Guarnizioni di battuta.

Pivoting door, mm 55 thick, with hollow-core structure. Door panel: unfinished with a primer coat, gloss or matt lacquered from the standard color range, vertical veneers from the standard range.
 Horizontal veneer on request.
 Header in pre-assembled anodized aluminium for direct wall installation. Subframe not necessary.
 Door striker seal.

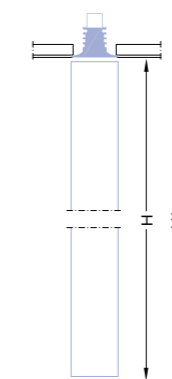
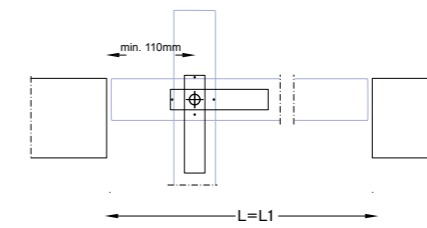

L
 luce netta / opening width
 700-900 mm 27 1/2" - 35 3/8"

H
 altezza netta / opening height
 max 3000 mm 118 1/4"

L1
 vano muro / rough opening
 L1 = L

H1
 vano muro / rough opening
 H + 53 mm

Altaj

Anta a battente in tamburato spessore mm 65 con bordo perimetrale in alluminio. L'anta può essere ridotta di spessore fino a 4 mm su entrambi i lati per accogliere rivestimenti di diversi materiali. Completa di serratura magnetica, cerniere a pivot a scomparsa, guarnizione perimetrale sui tre lati. Telaio in alluminio anodizzato preassemblato da murare senza falso telaio.

Hinged door in mm 65 thick hollow core with aluminium edging. The door can be reduced in thickness by up to 4 mm on both sides to accommodate coverings of different materials. Complete with magnetic lock, concealed pivot hinges and perimeter striker seals on three sides. Pre-assembled anodized aluminium frame that is set into the wall with no need for a subframe.

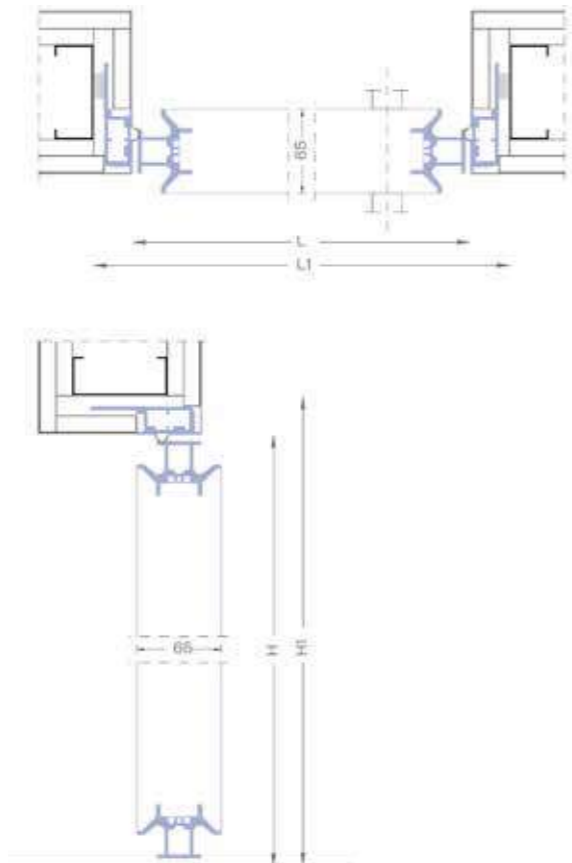

L
luce netta / opening width
780-830-880-930 mm
H
altezza netta / opening height
2120-2420-3020 mm
L1
vano muro / rough opening
L + 70 mm
H1
vano muro / rough opening
H + 30 mm

Ying

Anta a battente in tamburato di spessore mm 55 con bordo perimetrale in alluminio. La parte inferiore dell'anta è caratterizzata da una fascia in rovere con scanalature verticali, che rimane immutata per tutte le finiture della porta. Lo stipite in rovere ha la parte inferiore in finitura metallica color bronzo per l'anta in pelle. Completa di serratura magnetica, cerniere a pivot a scomparsa, guarnizione perimetrale sui tre lati. Telaio in legno con coprifili tridimensionali arrotondati.

Hinged door in mm 55 thick hollow core with aluminium edging. The lower part of the door features a strip in oak with vertical grooving, which is common to all door finishes. The lower part of the jamb in oak has a bronze-colored metal finish for the leather door. Complete with magnetic lock, concealed pivot hinges and perimeter striker seals on three sides. Frame in wood with rounded three-dimensional casings.

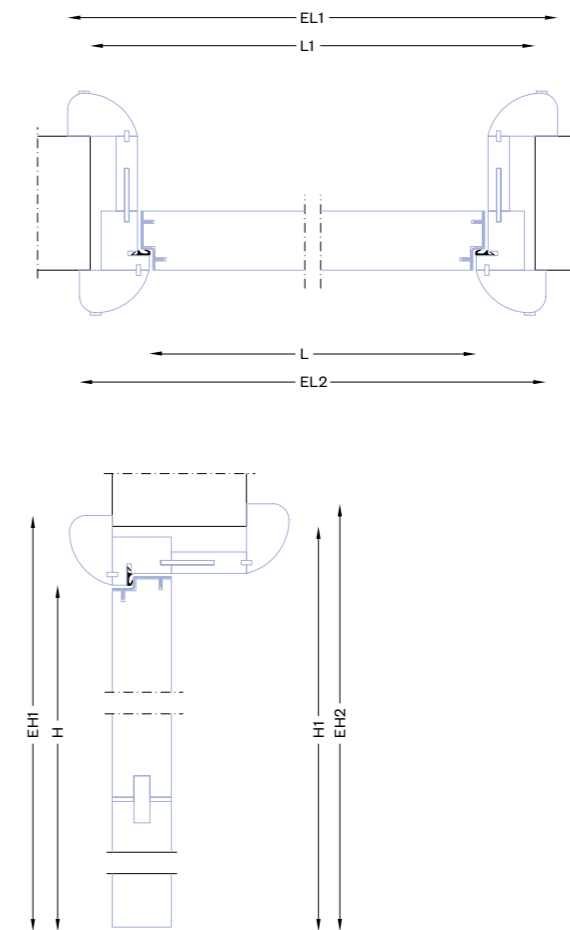

L
luce netta / opening width
700-800-900 mm
H
altezza netta / opening height
max 2900 mm
L1
vano muro / rough opening
L + 110 mm
H1
vano muro / rough opening
H + 55 mm
EL1
ingombro totale / overall sizes
L + 152 mm
EH1
ingombro totale / overall sizes
H + 65 mm
EL2
ingombro totale / overall sizes
L + 130 mm
EH2
ingombro totale / overall sizes
H + 76 mm

L7

L7 a battente, spessore 41 mm, con vetro di sicurezza 6 mm. Telaio perimetrale del vetro in alluminio trattato in diverse finiture. Cerniere a scomparsa, guarnizioni di battuta. Serratura magnetica. Sistema telescopico dello stipite da 100 a 130 mm. L7 con stipite telescopico in alluminio da montare su falso telaio dedicato.

L7 hinged door mm 41 thick in safety glass, mm 6 thick. Aluminium frame in different finishes. Concealed hinges and door striker seal. Magnetic lock set. Telescopic jamb from mm 100 to 130. L7 with a telescopic jamb to be installed on dedicated subframe.

L7 LARGE con stipite telescopico in alluminio da montare su falso telaio tradizionale.

L7 LARGE with a telescopic jamb in aluminium to be installed on traditional subframe.

L7

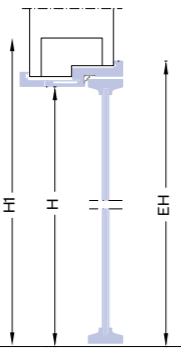
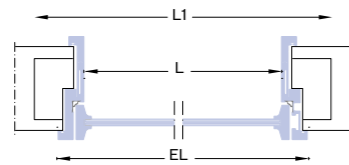

L
luce netta / opening width
600-900 mm 23 5/8"- 35 3/8"
H
altezza netta / opening height
max 3000 mm 118 1/4"
EL
ingombro totale / overall sizes
L + 59 mm
EH
ingombro totale / overall sizes
H + 30 mm
L1
vano muro / rough opening
L + 100 mm
H1
vano muro / rough opening
H + 50 mm

L7 Large

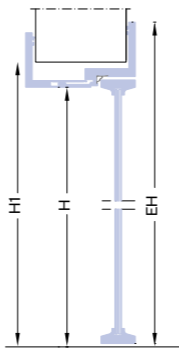
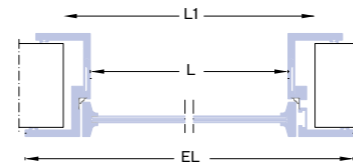

L
luce netta / opening width
600-900 mm 23 5/8"- 35 3/8"
H
altezza netta / opening height
max 3000 mm 118 1/4"
EL
ingombro totale / overall sizes
L + 190 mm
EH
ingombro totale / overall sizes
H + 96 mm
L1
vano muro / rough opening
L + 100 mm
H1
vano muro / rough opening
H + 50 mm

L41

Porta con battente a struttura tamburata di spessore 41 mm a lavorazione ultimata, con finitura laccato opaco, lucido ed essenze di serie; oppure con battente con telaio perimetrale in alluminio e lastre di vetro. Stipite in alluminio in diverse finiture. Guarnizioni di battuta. Cerniere a scomparsa. Montaggio su falso telaio dedicato.

Hinged door with a hollow core structure, mm 41 (1 3/4") thick. Finished in matt or gloss laquer or with a veneer from the standard range. Jamb in aluminium in a choice of finishes. Striker seal. Concealed hinges. Installation requires a subframe.

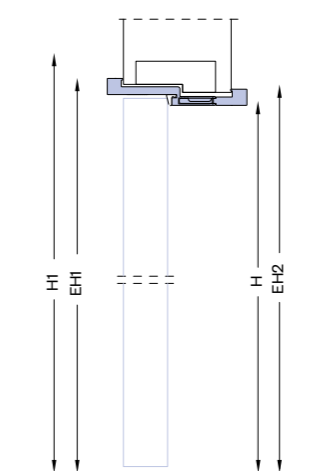
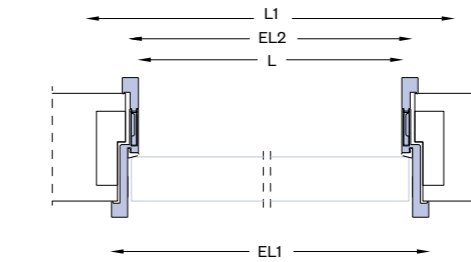

L
luce netta / opening width
600-900 mm 23 5/8"- 35 3/8"
H
altezza netta / opening height
max 3000 mm 118 1/4"
L1
vano muro / rough opening
L + 100 mm
H1
vano muro / rough opening
H + 50 mm
EL1
ingombro totale / overall sizes
L + 53 mm
EH1
ingombro totale / overall sizes
H + 27 mm
EL2
ingombro totale / overall sizes
L + 28 mm
EH2
ingombro totale / overall sizes
H + 15 mm

Lcd62

Porta a battente in tamburato, spessore 41 mm. Finitura in laccato opaco o lucido o essenze. Sistema telescopico dello stipite da 105 a 130 mm. Guarnizione di battuta. Reversibilità del senso di apertura. Cerniere a scomparsa. Montaggio su falsi telai tradizionali in legno. Disponibile anche in versione scorrevole esterna o a scomparsa.

Hollow-core hinged door, thickness mm 41. Finished in matt or gloss lacquer from the standard color range, or veneered. Jamb adjustable from mm 105 to 130. Door striker seal. Reversible opening. Concealed hinges. Mounted on traditional wood subframe. Also available in pocket and surface mounted sliding versions.

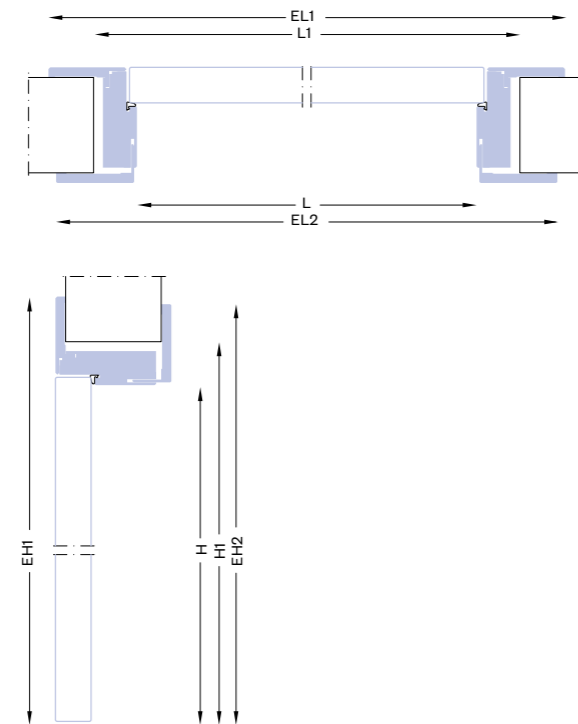

L
luce netta / opening width
600-900 mm 23 5/8" - 35 3/8"

H
altezza netta / opening height
max 2900 mm 114 1/4"

L1
vano muro / rough opening
L + 100 mm

H1
vano muro / rough opening
H + 50 mm

EL1
ingombro totale / overall sizes
L + 203 mm

EH1
ingombro totale / overall sizes
H + 102 mm

EL2
ingombro totale / overall sizes
L + 185 mm

EH2
ingombro totale / overall sizes
H + 93 mm

Filo 55 s-t

Porta a battente in tamburato, spessore 55 mm. Finitura in laccato opaco o lucido o essenze. Sistema telescopico dello stipite da 105 a 130 mm. Guarnizione di battuta. Cerniere a scomparsa. Montaggio su falsi telai tradizionali in legno. Disponibile versione scorrevole.

Hollow-core hinged door, thickness mm 55. Finished in matt or gloss lacquer from the standard color range or veneered. Jamb adjustable from mm 105 to 130. Door striker seal. Concealed hinges. Mounted on traditional wood subframe. Available as sliding door.

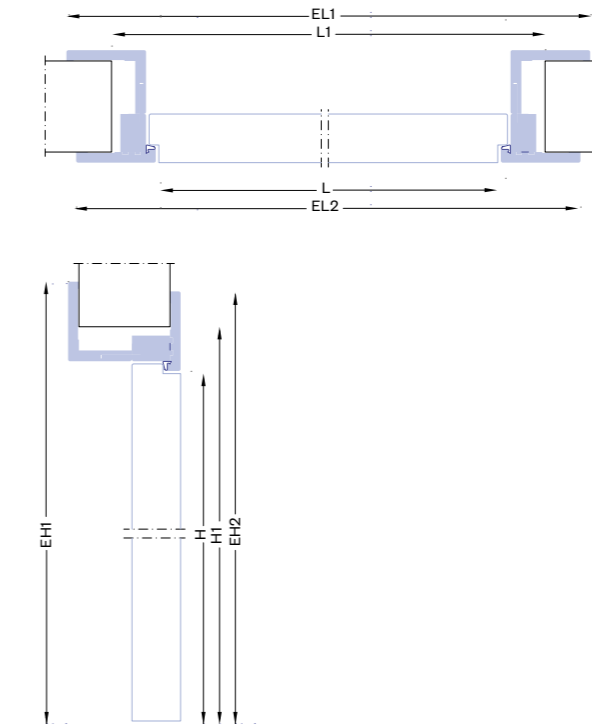

Filo s apertura a spingere / Push opening

L
luce netta / opening width
600-900 mm 23 5/8" - 35 3/8"

H
altezza netta / opening height
max 2900 mm 114 1/4"

L1
vano muro / rough opening
L + 100 mm

H1
vano muro / rough opening
H + 50 mm

EL1
ingombro totale / overall sizes
L + 203 mm

EH1
ingombro totale / overall sizes
H + 101 mm

EL2
ingombro totale / overall sizes
L + 181 mm

EH2
ingombro totale / overall sizes
H + 90 mm

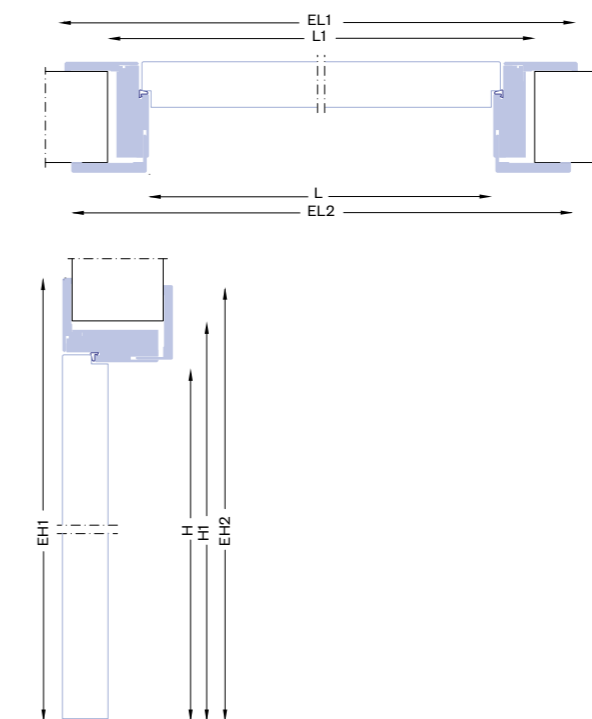

Filo t apertura a tirare / Pull opening

L
luce netta / opening width
600-900 mm 23 5/8" - 35 3/8"

H
altezza netta / opening height
max 2900 mm 114 1/4"

L1
vano muro / rough opening
L + 100 mm

H1
vano muro / rough opening
H + 50 mm

EL1
ingombro totale / overall sizes
L + 203 mm

EH1
ingombro totale / overall sizes
H + 102 mm

EL2
ingombro totale / overall sizes
L + 185 mm

EH2
ingombro totale / overall sizes
H + 93 mm

Avenue

Porta a battente tamburato spessore 41 mm con specchiature incassate a uno, due o tre riquadri. Battente e stipite laccati opaco nei colori di serie, stipite telescopico, guarnizioni di battuta e cerniere a scomparsa. Sistema telescopico dello stipite da 110 a 135 mm. Disponibile in versione scorrevole.

Hollow-core hinged door mm 41 thick with one, two or three recessed panels. Door panel and jamb in a matt finish from the standard color range, telescopic jamb, door striker seal and concealed hinges. Jamb adjustable from mm 110 to 135. Available also as sliding door.

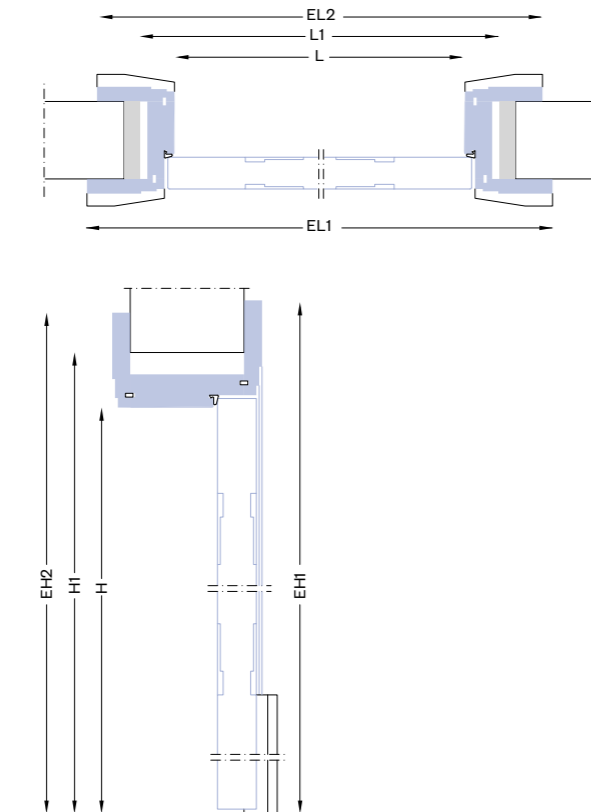

L
luce netta / opening width
600-900 mm 23 5/8" - 35 3/8"

H
altezza netta / opening height
max 2900 mm 114 1/4"

L1
vano muro / rough opening
L + 100 mm

H1
vano muro / rough opening
H + 50 mm

EL1
ingombro totale / overall sizes
L + 224 mm

EH1
ingombro totale / overall sizes
H + 112 mm

EL2
ingombro totale / overall sizes
L + 207 mm

EH2
ingombro totale / overall sizes
H + 103 mm

San Siro

Porta a battente in tamburato, spessore 41 mm, con specchiature incassate. Battente e stipite laccato opaco nei colori di serie. Sistema telescopico dello stipite da 105 a 130 mm. Guarnizione di battuta. Reversibilità del senso di apertura. Cerniere a scomparsa. Montaggio su falsi telai tradizionali in legno. Disponibile anche in versione scorrevole esterna o a scomparsa.

Hollow-core hinged door, mm 41 thick, with recessed panels. Door panel and jamb in a matt finish from the standard color range. Telescopic jamb from mm 105 to 130. Door striker seal. Reversible opening. Concealed hinges. Mounted on traditional wooden subframe. Pocket or external sliding versions also available.

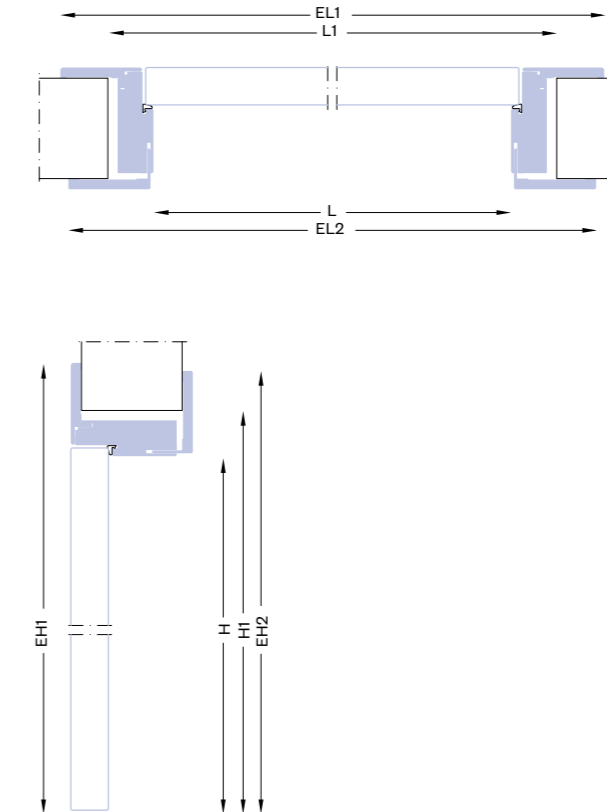

L
luce netta / opening width
600-900 mm 23 5/8" - 35 3/8"

H
altezza netta / opening height
max 2900 mm 114 1/4"

L1
vano muro / rough opening
L + 100 mm

H1
vano muro / rough opening
H + 50 mm

EL1
ingombro totale / overall sizes
L + 203 mm

EH1
ingombro totale / overall sizes
H + 102 mm

EL2
ingombro totale / overall sizes
L + 185 mm

EH2
ingombro totale / overall sizes
H + 93 mm

Drive

Porta scorrevole in tamburato da 41 mm. Bordi a sezione quadrata. Finiture dell'anta: essenze o laccato lucido e opaco nei colori di serie. Carrello a parete e rotelle di scorrimento a pavimento. Montaggio su muro presquadrato.

Hollow-core sliding door, mm 41 thick. Squared edges. Finishes: veneered, or gloss or matt lacquered from the standard color range. Wall hanger trolley and floor rollers. Installation on pre-squared wall.

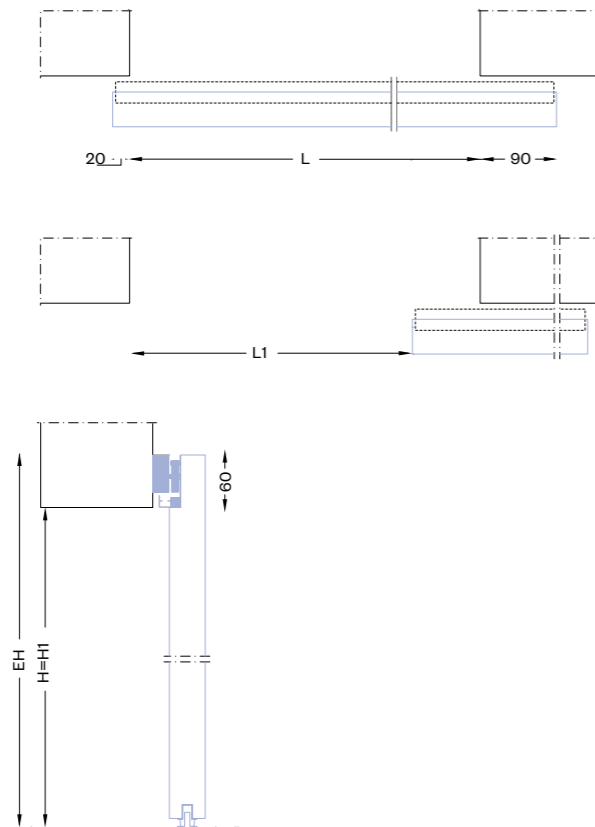

L
luce netta / opening width
700-900 mm 27 1/2" - 35 3/8"

H
altezza netta / opening height
max 3000 mm 118 1/4"

L1
luce passaggio / clear opening
L - 80 mm

EL
ingombro totale / overall sizes
L + 110 mm

EH
ingombro totale / overall sizes
H + 60 mm

Scorrevole a scomparsa senza stipite

Porta con anta a struttura tamburata di spessore 41 mm a lavorazione ultimata con finitura laccato opaco, lucido, essenze oppure con telaio perimetrale in alluminio e lastre di vetro. Maniglia ad incasso. Montaggio su cassaporta metallica.

Sliding-pocket without jamb. mm 41 (1 3/4") thick hinged door with hollow-core structure. Finishes available in matt or gloss lacquer or in glass with frame in aluminium. Flush handle. Installation requires a steel frame for stud wall.

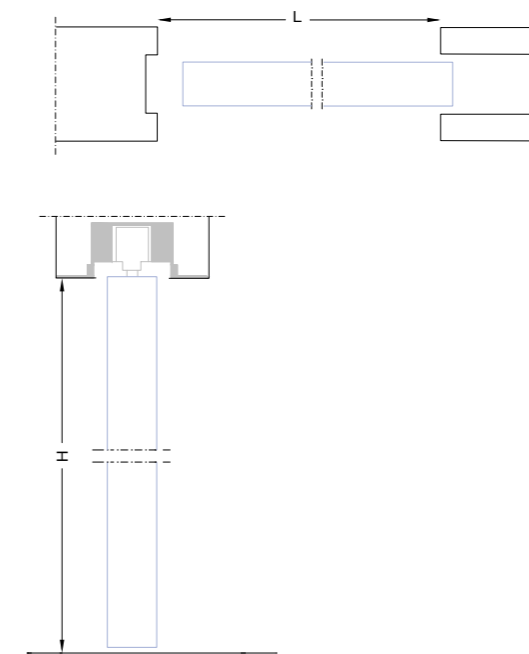

L
luce netta / opening width
600-900 mm 23 5/8" - 35 3/8"

H
altezza netta / opening height
max 2900 mm 114 1/4"

Wall&Door

Sistema costituito da pannelli fissi ed apribili realizzati su misura, entrambi prevedono una struttura tamburata di spessore 55 mm, finitura laccato lucido o opaco o in essenze di serie. Impiallacciatura orizzontale solo su richiesta. Completa di ferramenta, cerniere a scomparsa.

Wall system made of custom-made fixed and hinged panels. Hollow-core construction, mm 55 thick. Finishes available: vertical wood veneer, matt and gloss lacquered Horizontal veneer on request. Complete with hardware and concealed hinge.

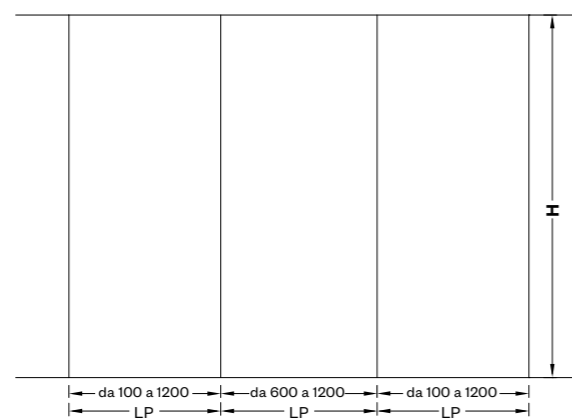
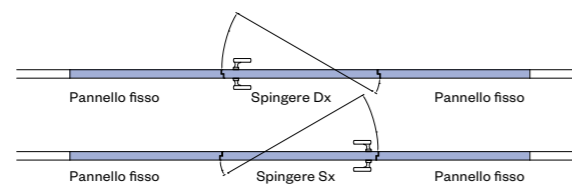
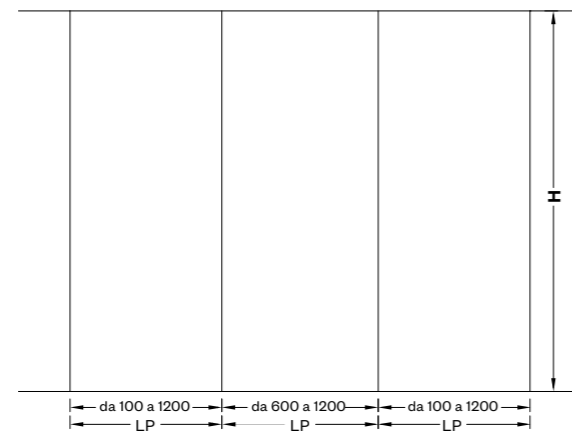
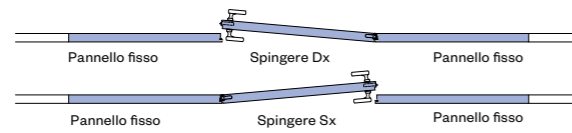

Wall&Door a battente / Swing door

LP
larghezza pannello fisso / width fixed panel
100-1200 mm
larghezza pannello apribile / width opening panel
600-1200 mm
H
altezza netta / opening height
max 3000 mm 118 1/4"

Wall&Door compass / Offset door

LP
larghezza pannello fisso / width fixed panel
100-1200 mm
larghezza pannello apribile / width opening panel
600-1200 mm
H
altezza netta / opening height
max 3000 mm 118 1/4"

Teatro

Sistema divisorio disponibile - sia nella versione ante libere (senza binario) che in quella sincronizzata - a due, tre, quattro, cinque o sei ante a bilico di spessore 55 mm. La soluzione è proposta completa di perni di fissaggio. Le porte hanno anta in legno e misure speciali con larghezza da 600 fino a 110. Le varianti includono chiudiporta a pavimento con fermo a 90° e decoro in metallo bronzato (per la versione ante libere) e sistema motorizzato sincronizzato, telecomando e decoro in metallo bronzato (per la versione sincronizzata).

Partition system composed by 55 mm-thick pivot doors and available both in the free panels version (without rail) and synchronized opening panel version. Configurable in different layouts: two, three, four, five or six panel system. The solution is offered complete with locking pins. The wooden doors have custom sizes with widths from 600 up to 110. Variants include a floor door closer with a 90° stop and a bronzed metal decoration (for the free panels version) and a motorized synchronized system, remote controller and bronzed metal decoration metal (for the synchronized opening panel version).

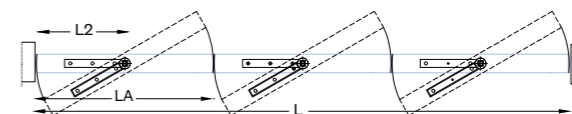
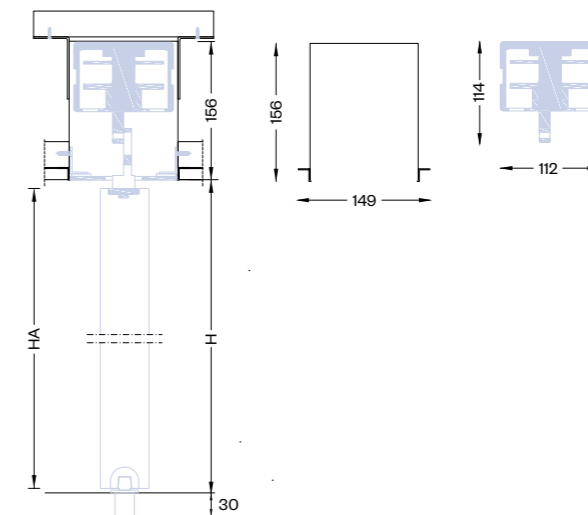

L
luce netta / net opening
H
altezza netta / opening height
LA
2 ante / 2 panel system = (L - 15 mm) / 2
3 ante / 3 panel system = (L - 20 mm) / 3
4 ante / 4 panel system = (L - 25 mm) / 4
5 ante / 5 panel system = (L - 30 mm) / 5
HA
H - 20 mm
L2
LA/2

Avenue Boiserie

Le boiserie Avenue vengono eseguite su disegno utilizzando pannelli con rilievo geometrico su un lato, nelle finiture laccato opaco.
Dimensioni: larghezza da 600 mm a 1200 mm; altezza fino a 2900 mm.

The Avenue boiserie is custom-made based on architectural drawings, using geometrically shaped panels on one side and available in matt lacquer finishes.
Dimensions: width from mm 600 (23 5/8") to mm 1200 (47 1/4"); height max mm 2900 (23 5/8").

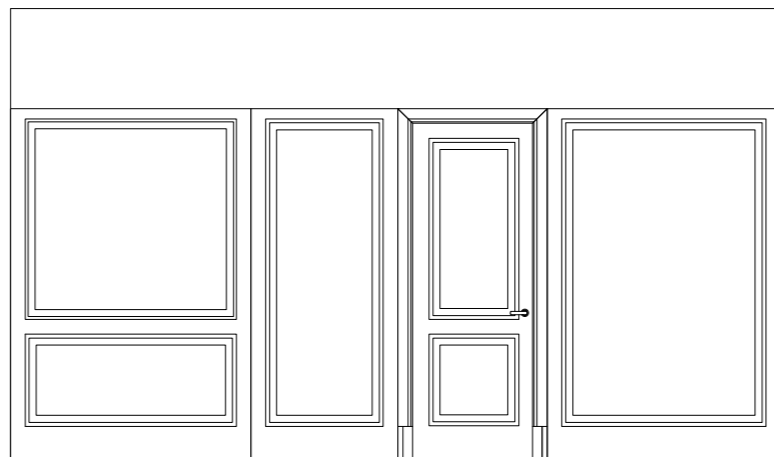
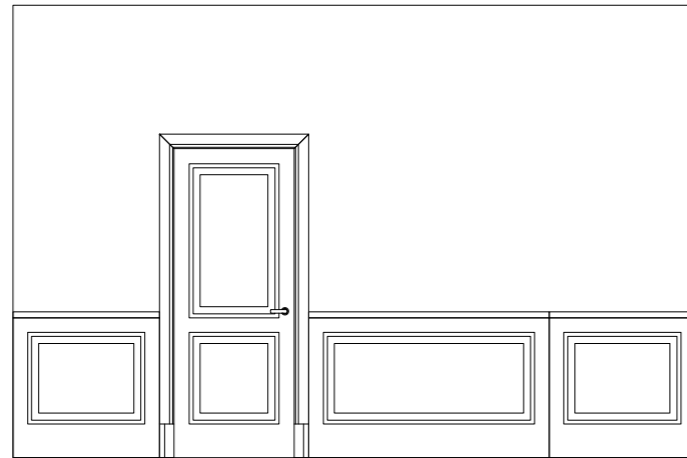

Edge Boiserie

Le boiserie Edge vengono eseguite su disegno utilizzando pannelli con rilievo geometrico su un lato, nelle finiture laccato opaco.
Dimensioni: larghezza da 600 mm a 1200 mm; altezza fino a 3000 mm.

The Edge boiserie is custom-made based on architectural drawings, using geometrically shaped panels on one side and available in matt lacquer finishes.
Dimensions: width from mm 600 (23 5/8") to mm 1200 (47 1/4"); height max mm 3000 (23 5/8").



Matrix

Battenti e scorrevoli: pannello in legno massello composto da tre diversi rilievi - A, B e C - accostati come da configurazione. Applicabile, solo a un lato, a: Rasomuro 55s, Compass 55 e ante scorrevoli con 50 mm di spessore.

Boiserie: pannello in legno massello disponibile con un solo rilievo a scelta tra A, B o C.

Hinged and sliding doors: solid wood panel composed of three different reliefs - A, B and C - as illustrated. Applicable on one side only to:

Rasomuro 55s, Compass 55 and mm 50 thick sliding doors.

Boiserie: solid wood panel available in one relief only - A, B, or C.

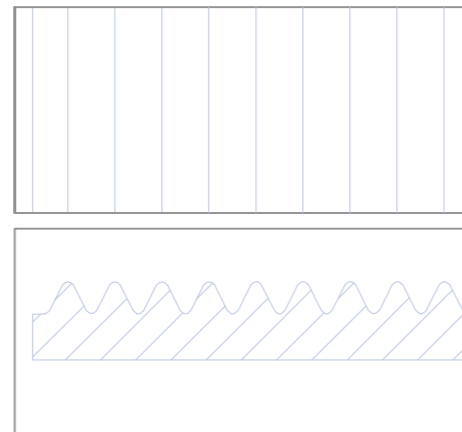

Tipo A / Type A

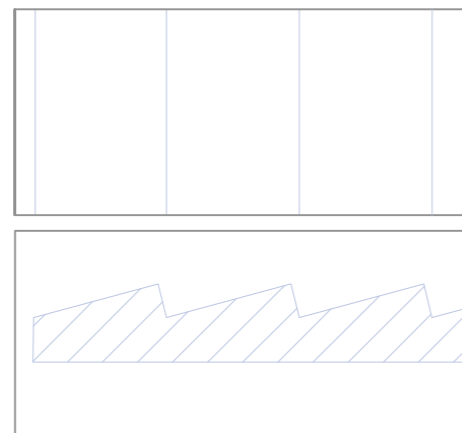

Tipo B / Type B

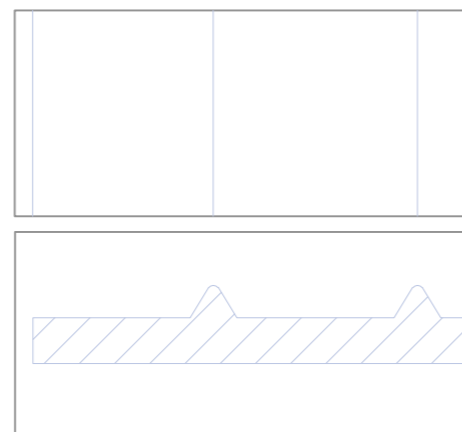

Tipo C / Type C

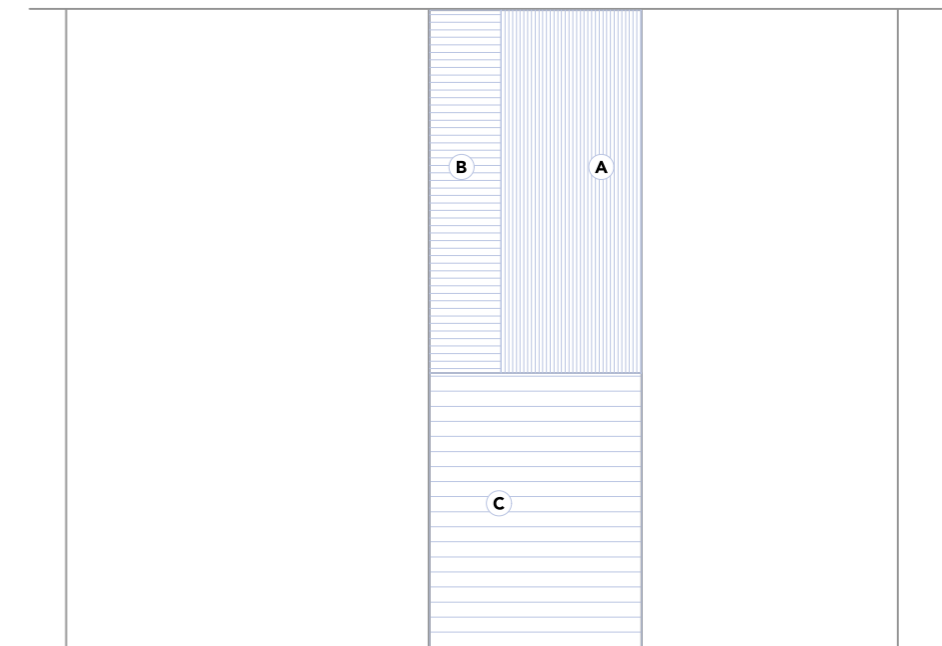

Configurazione Matrix per Rasomuro 55s / Compass 55 / Matrix layout for Rasomuro 55s / Compass 55

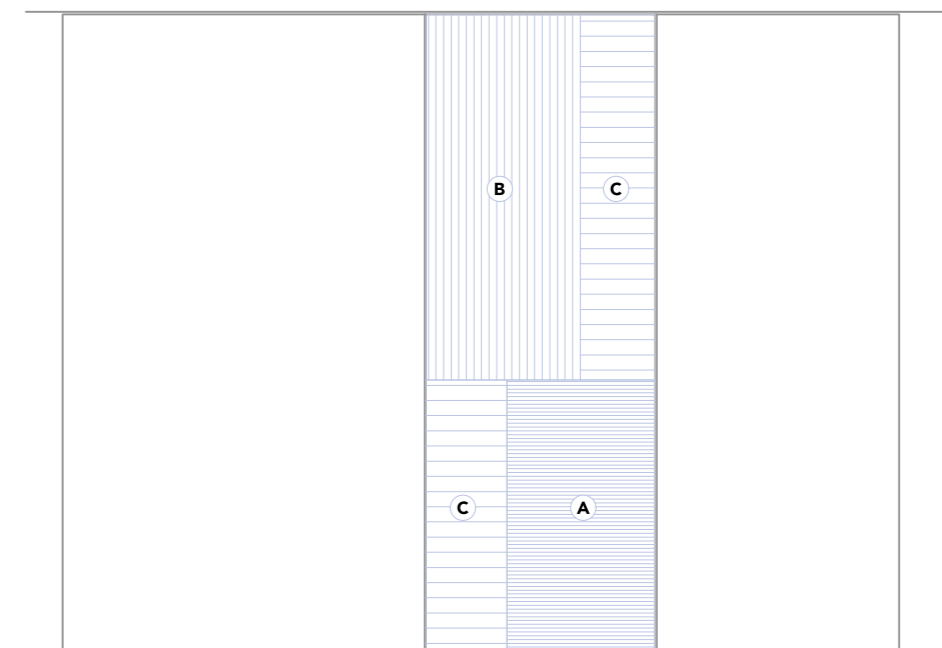

Configurazione Matrix per anta scorrevole / Matrix layout for sliding doors

Maniglie Handles

Push&Pull



A
Maniglia Push&Pull
cromo satinato /
Push&Pull handle
satin chrome



B
Nottolino Push&Pull /
Push&Pull privacy lock
Front / Back



C
Bocchetta yale /
Yale escutcheon

D
Bocchetta patent /
Patent escutcheon

Lualdi



A
Maniglia Lualdi
cromo satinato /
Lualdi handle
satin chrome



B
Nottolino Lualdi /
Lualdi privacy lock
Front / Back



C
Bocchetta yale /
Yale escutcheon

D
Bocchetta patent /
Patent escutcheon

Maniglie Handles

Martina



A
Maniglia Martina
cromo satinato, alluminio, bronzo, nero, bianco /
Martina Handle
satin chrome, aluminium, bronze, black, white



B
Nottolino Martina /
Martina privacy lock
Front / Back



C
Bocchetta yale /
Yale escutcheon

D
Bocchetta patent /
Patent escutcheon

Outline



A
Maniglia Outline
cromo satinato /
Outline handle
satin chrome



B
Nottolino Outline /
Outline privacy lock
Front / Back



C
Bocchetta yale /
Yale escutcheon

D
Bocchetta patent /
Patent escutcheon

Maniglie Handles

Edge



A
Maniglia Edge
cromo satinato /
Edge handle
satin chrome



B
Nottolino Edge /
Edge privacy lock
Front / Back



C
Bocchetta yale /
Yale escutcheon

D
Bocchetta patent /
Patent escutcheon

Ishi



A
Maniglia Ishi
cromo satinato, alluminio, bronzo, nero, bianco /
Ishi handle
satin chrome, aluminum, bronze, black, white



B
Nottolino Ishi /
Ishi privacy lock
Front / Back



C
Bocchetta yale /
Yale escutcheon

D
Bocchetta patent /
Patent escutcheon

Maniglie per porte scorrevoli Handles for sliding doors

CNQ Maniglia a incasso quadra CNQ Flush handle



A
Maniglia CNQ ad incasso quadra
cromo satinato, alluminio, bronzo, nero, bianco /
CNQ flush handle
satin chrome, aluminum, bronze, black, white



B
Nottolino CNQ /
CNQ privacy lock
Front / Back

CNT Maniglia a incasso tonda CNT Flush handle



A
Maniglia CNT ad incasso tonda
cromo satinato /
CNT flush handle
satin chrome



B
Nottolino CNT /
CNT privacy lock
Front / Back

Maniglie per porte scorrevoli
Handles for sliding doors

Ishi



A
Maniglia Ishi ad incasso
cromo satinato, alluminio, bronzo, nero, bianco /
Ishi flush handle
satin chrome, aluminum, bronze, black, white



B
Nottolino Ishi /
Ishi privacy lock
Front / Back

Maniglia Pomm
Pomm handle



A
Maniglia Pomm
cromo satinato, alluminio, bronzo, nero, bianco /
Pomm handle
satin chrome, aluminum, bronze, black, white

L7



A
Maniglia L7
cromo satinato, alluminio, bronzo, nero, bianco /
L7 handle
satin chrome, aluminum, bronze, black, white

Shoin



A
Maniglia Shoin
cromo satinato, alluminio, bronzo, nero, bianco /
Shoin handle
satin chrome, aluminum, bronze, black, white

**Vetri
Glasses**

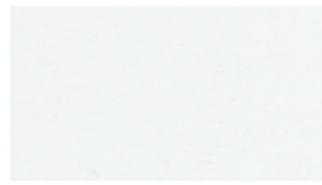

Trasparente extrachiaro
Transparent extraclear



Satinato extrachiaro
Satin extraclear



Extrachiaro riflettente
Reflective extraclear



Grigio trasparente
Transparent grey



Grigio satinato
Satin grey



Grigio riflettente
Reflective grey



Bronzo trasparente
Transparent bronze



Bronzo satinato
Satin bronze



Bronzo riflettente
Reflective bronze



Extrachiaro opalino
Opalin extraclear



Stratificato specchio
Laminated mirror

**Vetri speciali
Special glasses**



Flutes extra chiaro trasparente
Transparent extraclear fluted



Flutes grigio trasparente
Grey transparent fluted



Marks extrachiaro
Marks extraclear



Marks extrachiaro satinato
Marks satin extraclear



Retina metallica damier
Metallic damier mesh



Retina bronzo
Bronze mesh

**Vetri retrolaccati lucidi/satinati
Backpainted glasses**

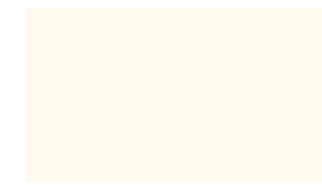

Bianco ottico
Pure white

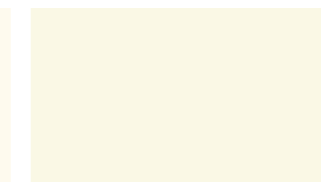

Bianco gesso
Chalk white

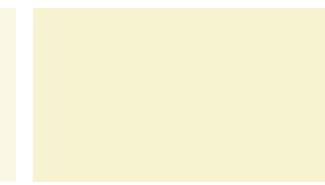

Avorio
Ivory



Grigio calce
Lime grey



Grigio tortora
Dove grey



Terra
Clay



Grigio ferro
Iron grey

**Profili
Profiles**



Alluminio naturale
Natural aluminium



Brill spazzolato
Brushed brill



Nero opaco
Matt black



Bronzo
Bronze

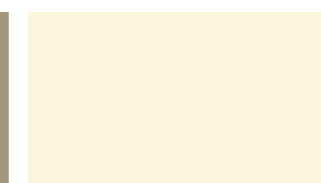

Bianco opaco
Matt white

**Colori laccato opaco/lucido
Matt/gloss lacquered finish**

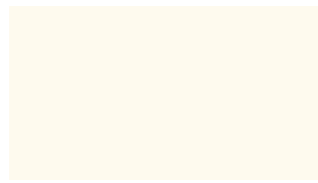

Bianco ottico
Pure white

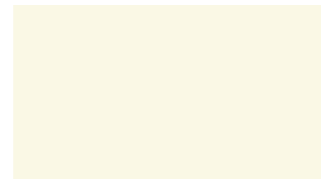

Bianco gesso
Chalk white



Avorio
Ivory

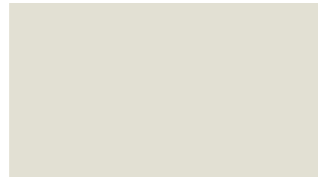

Grigio calce
Lime grey



Grigio tortora
Dove grey



Terra
Clay



Grigio ferro
Iron grey

**Cuoio / Pelle
Leather**



Pelle Intrecciata Moro
Woven leather Moro



Pelle liscia tortora
Dove grey smooth leather



Pelle liscia Moka
Moka smooth leather



Bordeaux
Bordeaux

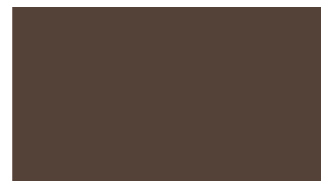

Brown
Brown

**Legni
Woods**

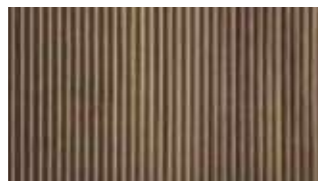

Matrix A

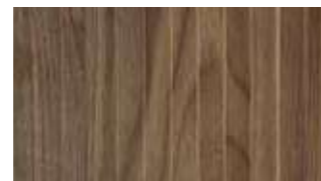

Matrix B

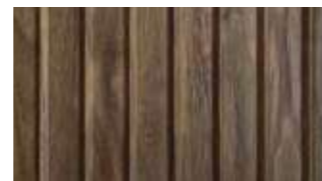

Matrix C

**Legni
Woods**



Rovere naturale
Natural oak



Rovere moka
Moka oak



Rovere thermowood
Thermowood oak



Rovere grigio
Grey oak



Rovere nero fossile
Black fossil oak

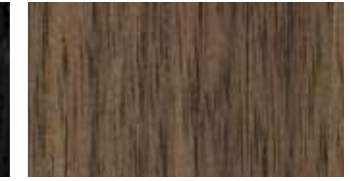

Noce canaletto
Canaletto walnut



Chocolat R rovere naturale
Chocolat R natural oak



Chocolat S rovere naturale
Chocolat S natural oak



Chocolat R nero fossile
Chocolat R fossil black



Chocolat S nero fossile
Chocolat S fossil black



Chocolat R noce canaletto
Chocolat R canaletto walnut



Chocolat S noce canaletto
Chocolat S canaletto walnut



Chocolat R rovere grigio su nero fossile
Chocolat R grey oak on fossil black



Chocolat S rovere grigio su nero fossile
Chocolat S grey oak on fossil black

Lualdi Spa

Via Kennedy
20010 Marcallo con Casone (MI)
T. +39 02 94363000
www.lualdi.com
info@lualdi.com

Showroom**Milano**

Foro Buonaparte 74
20121 Milano
T. +39 02 8052445
showroom@lualdi.com

Miami

Lualdi Inc.
318 NE 80th Terrace North
FL 33138
T. +1 305 576 4333
infomiami@lualdi.us

New York

584 Broadway, suite 1005.
New York, NY 10012
T. +1 212 334 4544
infony@lualdi.us

a.d. Graph.X

foto Giuseppe Brancato

styling Carin Scheve,
Alessandra Salaris

testi Giovanna Zoboli,
Patrizia Scarzella

traduzioni Richard Peace

retouching, pre press A. De Pedrini

stampa Nava Press 2021

I colori e le finiture, le illustrazioni e le descrizioni del presente catalogo sono a titolo indicativo. Lualdi spa si riserva il diritto di apportare, anche senza preavviso, modifiche di carattere tecnico e produttivo.

The colours, finishes, illustrations and descriptions in this catalogue are provided solely by way of example. Lualdi spa reserves the right to make technical and design changes without prior notice.

Thanks to:

Abc Italia
Almerich
Alizarina-Studio
Amaaro!
Amini
Anvia
Artek
Aym
Baxter
Bross Italia
Carl Hansen & Søn
Carré D'artistes Milano
CC-tapis
Co.arch Studio
Colè Gallery
Desalto
Draga & Aurel
Edizioni Design
Fabbian
Fantini Rubinetti
Flos
Fontana Arte
Francesca Verardo
Gallotti & Radice
Golran
Gt Design
Guaxs
Hk Living
Ilaria Innocenti
Inkiostro Bianco
Karpeta
Kristina Dam
La Cividina
Lema
Les Ottomans
Living Divani
Loloey
London Art
Luceplan
Mani Ceramics
Marca Corona
Menu
Meridiani
Midinette
Milano Parquet
Miniforms
MM Lampadari
My Home Collection
Nahoor
Nemo
Niki Jones
Paola Zani
Penta
Pietro Russo
Poliform
Porada
Porro
Potocco
Presotto
Pulpo
Restart
Roberta Licini
Rosenthal
San Giacomo
Sans Tabù
Servomuto
Shuj
Texturae
Venicem
Vetriere di Empoli
Vito Nesta per Les Ottomans
Vitra
Zanotta

